

Table of Contents

1	Undeveloped Ideas	2
	A Arrow's Information Paradox	3
	B Contract Law	6
	C Intellectual Property Law	10
	D Obstacles to Copying	12
	E Innovation	14
	F Near Miss: Debt Collection	18
	Problems	20
	<i>Idea Submission Questions</i>	20
	<i>Bizarro World Problem</i>	20
	<i>Lego Problem</i>	21

Undeveloped Ideas

To understand intellectual property law, it is necessary to understand the problems it tries to solve. It is not always easy to see these problems clearly in our actual world, where IP rights are abundant. Arguments about whether novelists would still write books without copyright are counterfactual, because books are protected by copyright, and have been for hundreds of years.

One way to see a world without IP is to look back in time, at what our world was like before the development of modern IP law. We will do this repeatedly in this book: to see why a particular IP regime is thought necessary, we will look at the arguments made for its initial enactment. Sound-recording copyright responded to specific perceived failures in the business of making music; plant patents and plant variety protections respond to specific perceived failures in the business of growing things.

But another way to see a world without IP is to look around today at the *negative spaces* of IP. These are areas where, for one reason or another, IP laws do not apply.¹ Examples (some of which we will examine in more detail) include fashion designs, recipes, sports plays, stand-up comedy, magic tricks, and roller-derby nicknames. For its own good and sufficient reasons, IP law has decided to leave these negative spaces alone, which means we can examine what happens in them, like cell cultures growing in a Petri dish, to see what happens in a miniature world without IP.

This chapter deals with one particular such negative space: the submission of undeveloped ideas. These ideas, for various reasons, fail to qualify for protection under the various bodies of intellectual property law. And yet they still have value, which means there are rewards to be reaped by anyone who can create them and get them into the right hands. Ideas are interesting because it can be surprisingly hard for people who have information to sell it to people who can make use of it. This chapter

1. See Elizabeth L. Rosenblatt, *A Theory of IP's Negative Space*, 34 COLUM. J.L. & ARTS 317 (2011).

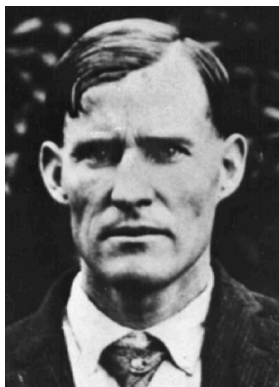

Floyd Collins (1887–1925)

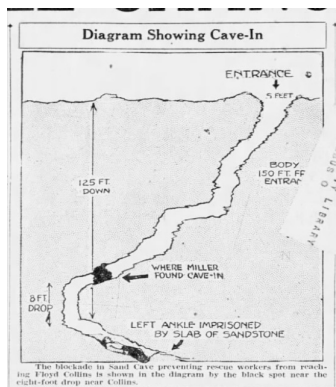

Diagram of the cave where Collins was trapped



Victor Desny (1906–79)



Billy Wilder (1906–2002)

is a case study in *transactability*: why people pursue deals for ideas, why those deals can be hard to make, how people sometimes manages to surmount those obstacles and make deals anyway, and what can go wrong when they try.

A Arrow's Information Paradox

The year was 1949, and a D-list actor named Victor Desny had a crack-erjack idea: someone should make a movie about the death of the caver Floyd Collins. Back in 1925, Collins had been exploring a cave in Kentucky when a rock fell on his leg, pinning him where he was and trapping him about 50 feet underground. At first, his friends were able to reach him from the cave's entrance, but then another cave-in made it too dangerous for them to continue. It took two weeks to dig a rescue shaft to reach him, but by then Collins had already died. Like the story of the Thai soccer team trapped in a cave in 2018, it was a media sensation, but with a tragic ending.

Like anyone else with a valuable idea, Desny had a choice to make. He could develop the idea himself, or he could sell the idea to someone else. Since Desny, like the vast majority of Americans in 1949, didn't have



Ace in the Hole theatrical poster

a movie studio of his own, or hundreds of thousands of dollars lying around, developing it himself was out of the question. So he picked up the phone and called the office of the director Billy Wilder at Paramount Studios. Wilder, one of the most commercially successful and critically acclaimed directors of Hollywood’s “Golden Age,” was responsible for classics including *Double Indemnity* (1945), *Sunset Boulevard* (1950), and *Some Like It Hot* (1960).

Desny’s plan was that Wilder would direct a movie based on the Floyd Collins story, that Paramount would produce and distribute it, and that he would be paid for suggesting it. The plan almost worked. Wilder did direct a movie based on the Floyd Collins story. It was called *Ace in the Hole*, and it starred Kirk Douglas as a newspaperman who manipulates the story in ways that sell papers but (spoiler alert!) ultimately lead to the unfortunate caver’s death. Paramount did release it. The movie was a commercial flop, taking in \$1.3 million for the studio as against a \$1.8 million budget, but its reputation has risen over time as its bleak perspective on the media has come to seem prescient. The only part missing, from Desny’s perspective, was the part where he got paid. Wilder and Paramount never called him back, sent him royalties, or acknowledged his existence.

Desny’s problem was that his big idea was an *idea* – a movie about Floyd Collins – and ideas are not protected by copyright, or by any other kind of IP. This means that anyone can do just what Wilder and Paramount did: use the idea without permission or payment, *even if they got the idea from someone else*. There are extremely good reasons that ideas are not protectable, but this negative space creates practical problems for people like Desny who have ideas and want to develop them. In the ab-

sence of a preexisting right to stop Paramount from using the idea for a movie about the tragic death of Floyd Collins, how can he negotiate with Paramount to sell it the idea to make a movie about the tragic death of Floyd Collins? As Justice Jesse Carter put it in a concurring opinion in *Desny v. Wilder*, the suit Desny filed once he realized that Paramount was making a Floyd Collins movie without him,

It should also be borne in mind that writers have no way of advertising their wares – that, as is most graphically illustrated by the present opinion, no producer, publisher, or purchaser for radio or television, is going to buy a pig in a poke. And, when the writer, in an earnest endeavor to sell what he has written, conveys his idea or his different interpretation of an old idea, to such prospective purchaser, he has lost the result of his labor, definitely and irrevocably. And, in addition, there is no way in which he can protect himself. If he says to whomever he is permitted to see, or, as in this case, talk with over the telephone, “I won’t tell you what my idea is until you promise to pay me for it,” it takes no Sherlock Holmes to figure out what the answer will be!²

This is *Arrow’s Information Paradox*, named for the economist Kenneth Arrow, who pinpointed the problem.³ Paramount wants to buy an idea for a hit movie, but it doesn’t want to pay until it knows enough about the idea to know that it’s a potential hit, and not an obvious flop. Desny wants to sell an idea, but he doesn’t want to disclose it until he knows that he’s going to get paid. The buyer wants to hear the idea first and then pay; the seller wants to get paid first and then describe the idea. In Arrow’s words:

There is a fundamental paradox in the determination of demand for information; its value for the purchaser is not known until he has the information, but then he has in effect acquired it without cost.⁴

The seller of a hammer or an orange can put it on a shelf and let potential buyers inspect it; the seller of information has no such option. Information is different. As legal scholar James Boyle observes, markets need information about the commodities being bought and sold to work, but when information is itself the commodity being bought and sold, the usual logic breaks down.⁵

2. *Desny v. Wilder*, 46 Cal. 2d 715, 754–55 (1956).

3. Kenneth J. Arrow, *Economic Welfare and the Allocation of Resources for Invention*, in *THE RATE AND DIRECTION OF INVENTIVE ACTIVITY: ECONOMIC AND SOCIAL FACTORS* 609 (1962).

4. *Id.* at 615.

5. JAMES BOYLE, *SHAMANS, SOFTWARE AND SPLEENS : LAW AND THE CONSTRUCTION OF THE INFORMATION SOCIETY* (1997).

The problem is especially acute for creators who can't commercialize undeveloped ideas on their own. If you have an idea for an improved design for a stepstool, you might be able to rent a small workshop space and start cranking out stepstools. But if, like Desny, you have an idea for a movie that will cost \$1.8 million to produce (about \$18 million in 2021 dollars, adjusting for inflation), you need to partner with a movie studio to produce it. In an important sense, Desny and Paramount need each other, and yet the nature of information makes it hard for them to trust each other.

B Contract Law

Ideas may not be protected as such, but that does not mean they are not protected at all. Even in a world without *intellectual property law*, there is still a baseline of *law*: property, contract, tort, criminal law, and so on all still apply. Paramount isn't allowed to send a squad of goons over to Desny's house to rough him up until he turns over his movie idea, any more than Desny is allowed to steal cash out of the safe on the Paramount backlot.

In particular, properly formed contracts are generally enforceable. Desny knew this. After he finished summarizing the story for Wilder's secretary and she promised to talk it over with the director, Desny emphasized that "I wrote the story and that I wanted to sell it," and the studio could use it only if they paid him "the reasonable value of it." She agreed, saying that if Paramount used it, "naturally we will pay you for it."

This was a contractual promise, or rather it wasn't, because under the American law of contracts, her promise was unenforceable. Reread the previous paragraph with your contract glasses on. Do you see the problem?

At the moment Wilder's secretary promised to pay, her promise was unsupported by consideration. Desny had already disclosed his idea for a movie about Floyd Collins. Paramount already had knowledge of the idea, which means that Desny wasn't giving anything up in exchange for the promise to pay, which made it an unenforceable gratuitous promise. As the court put it:

The idea man who blurts out his idea without having first made his bargain has no one but himself to blame for the loss of his bargaining power. The law will not imply a promise to pay for an idea from the mere facts that the idea has been conveyed, is valuable, and has been used for profit; this is true even though the conveyance has been made with the hope or expectation that some obligation will



Pre-computerization municipal bond certificate

ensue.⁶

The fact that *Desny* failed to contract around Arrow’s Information Paradox doesn’t mean contractual solutions are impossible. *Desny* tripped up on a technicality of consideration. Sellers who are more careful to dot their i’s and cross their t’s can avoid the traps of contract doctrine.

Consider the plaintiffs in *Apfel v. Prudential-Bache Securities, Inc.*⁷ Their big idea was to computerize the trading of municipal bonds, which at the time circulated as paper certificates. This too was an idea unprotected by intellectual property law. (The plaintiffs attempted to get a patent, but were unsuccessful.) They approached Prudential-Bache, an investment bank, and negotiated a sale of the idea in exchange for ongoing royalties. It was a striking success. Prudential was the first underwriter to use a computerized platform, and the rest of the municipal bond market rapidly switched over to computerized records.

But in 1985, Prudential stopped paying royalties and asserted that the contract was void for lack of consideration because “the ideas conveyed by plaintiffs had been in the public domain at the time of the sale agreement and that what plaintiffs sold had never been theirs to sell.” (“In the public domain” is the intellectual-property term of art for not being covered by any IP rights, so that anyone is free to do anything with the information.)⁸ But New York Court of Appeals⁹ upheld the contract in a 1993 opinion, finding that it was supported by consideration. To see why, consider the court’s description of the contracting process:

6. *Desny*, 46 Cal. 2d at 739.

7. *Apfel v. Prudential-Bache Sec., Inc.*, 81 N.Y.2d 470 (1993).

8. *Id.* at 474.

9. New York’s highest court.

Initially, the parties signed a confidentiality agreement that allowed defendant to review the techniques as detailed in a 99-page summary. Nearly a month of negotiations followed before the parties entered into a sale agreement under which plaintiffs conveyed their rights to the techniques and certain trade names and defendant agreed to pay a stipulated rate based on its use of the techniques for a term from October 1982 to January 1988.¹⁰

Pay close attention to the sequencing of the negotiations. Where Desny “blurted out” his plot synopsis, Apfel and his partner first made Prudential sign a confidentiality agreement, under which Prudential promised *not* to use the idea without paying. This contract was supported by consideration: in exchange for the promise of confidentiality, Prudential got the plaintiffs to tell it about their idea for computerized bond trading. Before signing this agreement, Prudential would have been free to implement a computerized municipal bond system if it had designed one on its own. It gave up that right by promising not to use or disclose what the plaintiffs were about to show it in their 99-page summary. This meant that the second contract, the one in which Prudential actually agreed to pay royalties, was also supported by consideration. In that second contract, the plaintiffs gave Prudential the right to use the system again – the very system it had agreed not to use in the first contract.

Desny’s mistake, then, was describing his movie idea *before* extracting the promise to pay for its use, or at least a promise not to use it without his permission. It’s a bit frustrating that contract doctrine and idea-submission cases can turn on which of two sentences came first. But if you find that kind of legal hair-splitting infuriating, you should probably put this book down and find something else to do, because law is full of such arbitrary distinctions. From a deal-maker’s perspective, the best practice is simple. First, get the non-disclosure agreement (NDA) locked down. Then share the information. If the buyer likes it, it can pay the seller in exchange for a partial release from the NDA.

Problem solved, then? Not quite. What if the Prudential technologists who read through Apfel’s pitch book discover that it merely rehashes the same basic idea their own group has been working on for two years? It might seem that this is fine: Prudential has gained nothing but it has lost nothing, either, and this is why payment is deferred to the second stage of negotiations. But Prudential has indeed lost something: it has made a contractual promise not to use Apfel’s idea without paying. It can use its own design for a computerized municipal-bond trading platform, but it cannot use Apfel’s design. This distinction breaks down when the two designs are similar. If Prudential goes ahead without paying, the ensuing litigation will turn on the issue of whether Prudential’s design

10. *Apfel*, 81 N.Y.2d at 474.

was not just *similar* to Apfel's idea, but in fact *copied* from it. These lawsuits are often fact-intensive and unpredictable, because they can turn on detailed questions of who knew what when.

Contract design can help with this problem, but not entirely solve it. Prudential's lawyers, anticipating the risk that signing an NDA with Apfel could lock Prudential out from using an idea it already had, will want to add a clause that they are free to use the idea in such circumstances. But Apfel's lawyers will object. If the idea really is new to Prudential, what's to stop Prudential from lying about already knowing the idea and then immediately turning around to implement it? They will want to add a clause that Prudential cannot use the idea at all, regardless of whether it had been copied from Apfel's disclosure or not. Prudential's lawyers will object that they cannot possibly promise not to use Apfel's idea without first knowing what it is. This dilemma should sound familiar: it is simply Arrow's Information Paradox in new clothes and a different haircut.

The *Apfel* court was able to sidestep this issue. Look again at the ordering of the deal. Prudential agreed to pay millions of dollars in exchange for the right to use an idea *it already knew*. If it thought the idea was worthless, it could have just walked away. When "the buyer knows what he or she is buying and has agreed that the idea has value, and the Court will not ordinarily go behind that determination."¹¹ This is another point in favor of the two-step contracting process. Provided that the parties trust each other enough to enter into a contract for an initial disclosure, the actual contract for use is made between parties who know what they are bargaining over and no longer face Arrow's Information Paradox. The hard part is getting to that point. Many companies have a blanket policy of refusing to look at unsolicited idea submissions; others impose terms that make it clear they have no obligations whatsoever.

To summarize, even when there are no IP rights in information, it can still be valuable. It was worth Apfel's time to develop an idea for a computerized trading system, it was worth Prudential's time and money to implement it, and it was possible for them to agree on terms of sale (even if Prudential tried to weasel out of the deal later). For some kinds of information, at least, IP rights as such are not necessary, and the world functions well enough without them. Ordinary contract law is good enough for some purposes.

C Intellectual Property Law

Here is yet another variation on the same basic pattern. Maurice "Mo" Pinel was convinced that making a bowling ball's heavy inside "core" asymmetrical would give it "an organic wobble that would bend it toward

11. *Id.* at 478.



Maurice “Mo” Pinel (1942–2021)

the pins over the final third of a lane.”¹² After making a few prototypes and confirming that they worked, he approached potential business partners:

Never lacking confidence, Pinel contacted several ball manufacturers in 1973 and proposed a deal: If they would sign a nondisclosure agreement, he’d brief them on his experimental results and help them design balls that would allow amateurs and pros alike to increase their strike rates. Company executives responded that they were willing to listen to Pinel’s ideas, but he was the one who would have to sign a release affirming that nothing he said was confidential. Miffed by what he saw as attempts to steal his ideas, Pinel veered away from a career in ball design.¹³

Arrow’s Information Paradox, yadda yadda yadda, but pay attention to what happened later:

Pinel drew up a variety of designs for asymmetric ball cores, then, in April 1990, filed a patent for his favorite. It was a bulbous hunk of polyester with both a central indentation and a conic tail, and portions of it resembled the sides of an octagon. (The best visual analogy may be a top-down view of Master Chief’s helmet in the video game Halo, but that’s a gross oversimplification.) . . .

Shortly after submitting his patent, Pinel received a call from Phil Cardinale, [who had] been hired to revive a financially troubled ball brand called Star Traxx, which he had renamed Track. He re-

12. Brendan T. Koerner, *One Man’s Amazing Journey to the Center of the Bowling Ball*, WIRED, July–Aug. 2021, <https://www.wired.com/story/one-mans-amazing-journey-to-the-center-of-the-bowling-ball/>.

13. *Id.*

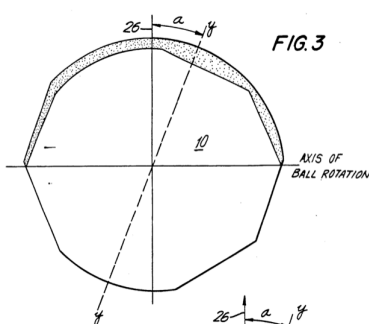

Pinel's asymmetrical design



Track Shark bowling ball

called Pinel's napkin sketches of unorthodox cores and invited him to help design a new Track ball. It was a one-time chance to test out whether his theories would hold up in the real world.

Pinel seized the opportunity. He created a core based on the "tip-and-tail" concept he'd just applied to patent. The resulting ball, the Shark, flared even when a bowler didn't apply much spin at the moment of release.

Pinel's asymmetrical cores revolutionized bowling-ball design, and he went on to achieve fame and fortune as the designer of AMF's Sumo, Fa-ball's Hammer 3D Offset, and other strikingly successful bowling balls.

The key difference in Pinel's story is his patent, No. [5,037,096](#). We will have much more to say about how patents work in the Patents chapter, but the core relevant fact is that no one can make, use, or sell a patent invention without the permission of the patent owner. If Track had manufactured the Shark without paying Pinel for permission, he could have sued for royalties and an injunction to force Track to stop.

This "exclusive right" allowed Pinel to negotiate with Track in the first place. He could disclose the tip-and-tail asymmetric core to Track without worrying that Track would break off negotiations and manufacture it. Indeed, part of the patent bargain is that the details are published: Pinel could simply have sent Track a copy of the patent with a sticky note saying "Let's talk terms." At this point, Pinel and Track were in the same happy place as Apfel and Prudential post-NDA. They could focus on finding a mutually agreeable deal.

In other words, one justification for IP rights is that they can help to resolve Arrow's Information Paradox and make contracting over information feasible. They do so by preventing the recipient of information from using it. The buyer knows enough about the information to negotiate over it, but they are not free to do what they want with it. Paradoxically, this *ex post* restriction on what they can do with information can make them better off *ex ante*, because idea "men" of all gender identities will

be more willing to start the negotiations in the first place, just like Pinel did once he had a patent.

D Obstacles to Copying

All three stories so far – Desny and Paramount, Apfel and Prudential, Pinel and Track – have involved contracts for the *development* of information-based products: a movie, a trading platform, a bowling ball. These are basically one-to-one contracts between someone with an idea and a company with the resources to develop that idea into a full-fledged product. Sometimes, this may be enough to commercialize an idea. But often, more is needed.

The final step for many information-based goods is sale to paying customers. Viewers bought tickets to see *Ace in the Hole*, municipal bond traders paid to connect to Prudential’s system, and bowlers bought Sharks. These too depend on contract law; they involve contracts between a *distributor* like Paramount, Prudential, or Track and a relevant segment of the public.

If you have learned anything at this point from this chapter, you should now be asking whether and how Arrow’s Information Paradox applies to the negotiations over *these* contracts. What is to stop viewers of *Ace in the Hole* from showing in their own movie theaters without paying royalties, or from making their own Floyd Collins movies? What prevents them from creating their own muni-bond trading platforms, or their own tip-and-tail asymmetrical-core bowling balls?

There are five kinds of answers to this question, one bad and four good. The bad answer is that the same contract-law techniques that work for development will also work for distribution. Just make every buyer of a Shark ball sign an NDA. That’ll work, right? The theoretical enforceability of such contracts is almost beside the point. Suppose that Field Bowling Equipment releases a Killer Whale ball that is basically a Shark clone. Track has no contract with Field,¹⁴ so it cannot sue Field for breach. The only way that contract law will help Track is if it can find and sue the specific buyer who leaked a Shark to Field, an infeasibly difficult task. The structure of contract law is not well suited to keeping control over information made available to a wide audience.

A better answer is that IP rights also work for disclosure to the public. Track has a patent – Pinel’s patent, in fact – on the design of the Shark. That keeps Field, and anyone else, from making, using, or selling identical balls. Similarly, *Ace in the Hole* was protected by copyright; unlicensed exhibitions and too-similar ripoffs both infringe. Idea-submission cases are a specific negative space where IP protections do not apply, but

14. The technical contract term is that there is no “privity of contract” between them.

frequently unprotectable ideas can be worked up into protectable products.

A second good answer is that some information is hard to copy from products based on it. In 1951, a viewer in a movie theater could not easily make a good replica of the film on screen. Theaters could screen *Ace in the Hole* without worrying that the thousands of people who saw it each week would make their own copies. All the theaters had to do was maintain reasonable security over the canisters containing the film reels, a much easier problem. This works better for some information than others: a Shark bowling ball is easy to cut open. Prudential's bond-trading platform is an interesting middle case. The trading platform revealed the general concept to any user, but the software implementing it remained on Prudential's computers, where users could not inspect the details.

A third good answer is that sometimes copying is fine because there are structural features of the product market that allow the creator to recoup their investment before copying becomes a problem. Movies take months or years to make and cost millions of dollars. Even leaving copyright law aside, by the time another studio could have produced and released its own Floyd Collins movie, *Ace in the Hole* would already have completed its initial theatrical run, on which its financial success hinged. Similarly, an electronic trading platform is complicated, expensive, and slow to create. Prudential's was already well-established by the time competitors had their up and running. Bond traders need to be on a trading platform with other traders, so network effects will tend to protect an established platform from later-arriving competitors. On the other hand, there are fewer such structural barriers in the bowling-ball market; a bowling ball is a relatively straightforward object.

A final good answer is that sometimes people who *could* practically and legally copy a product will *choose* not to because there are informal non-legal social norms against doing so. Stand-up comedians, for example, enforce a norm against copying jokes, even though copyright law is mostly ineffective at protecting jokes.¹⁵ Comedians who steal jokes poison their reputation among their peers and have a harder time getting gigs. These norms typically work better in tight-knit communities; it is safe to say that there is no widely-shared anti-copying norm among the entire population of the United States.

IP rights, then, can help solve a contracting failure in consumer markets for products based on information. Here, the contracting failures are more severe, because contract law itself is not so much help. But the structural features of these markets don't always mean that IP rights are necessary. The interior design of most new bowling balls – and there are

15. Dotan Oliar & Christopher Sprigman, *There's No Free Laugh (Anymore): The Emergence of Intellectual Property Norms and the Transformation of Stand-Up Comedy*, 94 VA. L. REV. 1787 (2008).



Joe Rogan confronting Carlos Mencia for copying other comedians' jokes (2007)

a *lot* of new bowling balls – is not protected by any IP rights. Pintel's patent was relatively unusual.

E Innovation

The story so far is that some kinds of information-based products cannot be effectively commercialized through contract law alone. Imagine a world in which there is no IP and no technical, structural, or norm-based obstacles to copying. In this world, Paramount knows that as soon as it releases *Ace in the Hole* to theaters, pirates will make perfect copies and start showing them in other theaters.

The standard story about what happens next is that the price of tickets to watch *Ace in the Hole* will collapse. Movie tickets circa 1950 cost about 50 cents. Just to make up numbers, suppose that half of this amount (25 cents) consists of a movie theater's *operating costs* to keep the lights on, the floors clean, the projectionist paid, etc. The other half (25 cents) is paid out as *royalties* to Paramount. Since the authorized theater charges 50 cents a ticket, the pirate theater will charge 45 cents instead. The pirate theater will be packed while the authorized theater sits empty. Since it has to cover its operating costs, the authorized theater will cut its own price to 45 cents and tell Paramount, sorry, if you insist on the full 25-cent royalty, *Ace in the Hole* will play to empty houses. Paramount will grudgingly accept a reduced 20-cent royalty . . . but then the pirate theater will cut its ticket price to 40 cents, and the cycle will repeat until both theaters are screening *Ace in the Hole* at just above their breakeven point of 25 cents per ticket.

In economic terms, information goods like *Ace in the Hole* are *non-excludable* and *non-rival*. Non-excludability is Arrow's Information Paradox: other than by keeping information secret, it is not possible to restrict

access to it. A roller coaster is excludable. The ride attendant can ensure that only people who have paid for a ticket are allowed to ride. But information is non-excludable, because once the information is revealed to one other person, they can pass it along to anyone else they want. Non-rivalry means that any number of people can simultaneously make use of the same information. A roller coaster is rival, because it can only hold a few people at a time. But a movie is non-rival, because one person's entertainment doesn't detract from anyone else's. Non-excludability and non-rivalry together are what make price-cutting competition by copyists possible.

Theaters can survive as long as they cover their operating costs, but this state of competition is ruinous for Paramount, which paid \$1.8 million to make *Ace in the Hole* in the first place. At a 25-cent royalty on a 50-cent ticket, it needs 7.2 million people to pay for admission to reach the point at which it breaks even on its investment. At a 0-cent royalty on a 25-cent ticket, Paramount will *never* recoup its investment, which means that if its executives are at all rational, they will get out of the movie business and get into something with more workable economics, like real-estate speculation or manufacturing surfboards, and *Ace in the Hole* will never get made.

Again, in economic terms, information goods like *Ace in the Hole* have high *fixed costs* to produce in the first place, but low or zero *marginal costs* to make additional copies of. One of the basic results of microeconomics is that competition drives the price of a good down to its marginal cost – like the two movie theaters cutting their ticket prices down to 25 cents. Paramount's royalty is an expense that the authorized theater but not the pirate has to pay, which it cannot sustain if the two have to compete. From Paramount's perspective, that royalty is necessary to make the movie in the first place, which means that *perfect competition is incompatible with producing high-fixed-cost information goods*.¹⁶

This, then, is the conventional utilitarian story of IP as a driver of creativity and innovation. Because information is non-rival and non-excludable, it will be copied freely by competitors unless IP law prevents them. And because information has high fixed costs and low marginal costs, it will not be produced in the first place unless this copying can be stopped. Exclusive rights in information provide an *incentive* for innovation by enabling creators to make a profit. This incentive is calibrated to consumer demand: the more the public is willing to pay for something, the greater the incentive to create it.

This story is persuasive *given its two assumptions*. They are (1) that there are no other barriers to copying, and (2) that the costs of innova-

16. If you like, confirm to your satisfaction that this is still the case if Paramount owns and operates its own theaters.

tion must be recovered by commercializing the results. We have seen above that (1) can fail: contract law, technology, market structure, and social norms can all sometimes limit copying. And as for (2), direct commercialization is not and has never been the only mechanism to finance creativity and innovation. It is one particular legal strategy, which supports particular business models. But there are other models that do not rely on the existence of exclusive rights. Here are some variations.¹⁷

- Media companies—books, movies, software, podcasts, etc.—are in the business of *selling information*. Of course, there are numerous variations: “selling” includes rentals, subscriptions, advertising along with content, and so on. But the general idea is simple: customers are paying to get access to information itself.
- Many other companies—everything from auto manufacturers to restaurants—are in the business of *using information*. They provide goods or services, and innovation lets them provide better goods or services more cheaply.
- In *patronage*, an external sponsor wants information that doesn’t already exist, so they pay someone to create it. This category includes grant funding, as when the National Science Foundation supports research on cancer genomics or a charitable arts foundation commissions a new play.
- In *crowdfunding* (in the style of Kickstarter or Patreon), a creator proposes a project and solicits funders. Sometimes it’s closer to philanthropy, and sometimes it’s closer to selling information or goods. But the interesting common thread is that the funders are collectively catalyzing creativity by committing *in advance* to support it.
- Many people pursue *passion projects* based on their own intrinsic motivation. People who post stories on An Archive of Our Own or illustrations on DeviantArt generally have no expectation of direct financial return. They do it because they love to create, and to share with others.
- *Open source* projects, like the Linux operating system, are heavily supported by the volunteered efforts of participants. There are often elements of patronage (participants want the world to have high-quality software), crowdfunding (participants rely on each others’ contributions to make the project feasible), and passion (participants enjoy their work and take pride in it).

Most real-world innovation and creativity is a hybrid of one or more

17. This list is derived from Benjamin Reinhardt’s list of eight “innovation channels”: Benjamin Reihardt, *Innovation Channels* (Oct. 19, 2018), <https://benjaminreinhardt.com/innovation-channels/>.

of these channels, and it is common for projects to shift among them over time. Some passion software projects turn into open-source projects when the creator realizes they may be useful to others. An photographer supported by an philanthropic fellowship can still sell prints of her photographs. Grant-funded university research can be spun out into commercial startups, or a software business may decide to open-source its key product, both out of altruism and to attract outside developers with a stake in its success.

The point, for our purposes, is that *not all of these channels require exclusionary commercialization via IP rights*. Consider a Kickstarter for a new downloadable print-and-play role-playing-game. The 100 funders who kick in \$50 each don't care whether other people also get to play. Indeed, a community of fellow players will make the game *more* fun from their perspective. As long as the game gets made, they consider their \$50 well spent. There is still a version of Arrow's Information Paradox here: how is it that funders can trust that the game they are backing will be any good? But IP rights don't have to be the solution.

F Near Miss: Debt Collection

Thinking about IP as a system for controlling information often yields insight into non-IP bodies of law, and vice versa. Here is an example, in which the nature of information helps explain the dysfunctional dynamics of an industry.

Debt collection is a shady, high-pressure business. Collection agencies buy unpaid debts in bulk from lenders and from each other, usually for a fraction of the face value of the debts. What does it mean to "buy" debts? The buyer receives an assignment of the seller's right to collect the debt. But that assignment of a right to bring a collection action is practically useless without metadata: information about the debts. Thus, the buyer typically also receives a spreadsheet listing the debtors, their addresses, the amounts they owe, and perhaps some information about previous failed attempts at collection. Then the buyer goes to work, calling the debtor, sending letters, negotiating payment schedules or write-downs of the debt in exchange for partial payment, and threatening legal action and perhaps following through.

Unsurprisingly, debt collectors are known to use sharp tactics, including issuing unfounded legal threats, making repeated calls, trying to collect on debts that have been discharged in bankruptcy or where the statute of limitations has expired, and sometimes even intimating the possibility of violence. The federal Fair Debt Collection Practices Act (FDCPA) and numerous state laws try to prevent these abusive tactics. Here is another:

Around the same time that Theresa was getting phone calls from a

mysterious law firm, Siegel received an email from the owner of an agency that he had hired to do his collecting. The collectors at this agency were getting the same message from many debtors: We just paid off these accounts – to someone else. Siegel was both flummoxed and concerned. Was this the work of a renegade collector at one of his agencies who was collecting on his own and pocketing the cash? Or had the paper simply been stolen from his offices?

The notion that a portfolio of debt could be stolen may seem improbable, but plenty of debt brokers are all too willing to sell “bad paper.” Such brokers sometimes “double sell” or “triple sell” the same file to multiple unsuspecting buyers. Other times, a broker may sell paper that he does not own and obtained by nefarious means. I spoke at length with one debt broker from Buffalo, who told me that he had hired a hacker from China to break into a former client’s email account and obtain his password. Once he had the client’s password, the broker had access to his paper. He then simply took a portfolio and, subsequently, sold it to another buyer – who didn’t know and didn’t ask where it came from.¹⁸

This is not strictly speaking an IP problem. The right to collect an unpaid debt is a contract right, which functions as a kind of property when it is assigned from the original lender to a debt collector. And there is no copyright or other IP right in the metadata about debts, regarded as information. They are simply facts about the world, which no one can own. And yet the unrestricted copying of debt portfolios has unpleasant consequences for debt collectors and ruinous ones for borrowers. Because the spreadsheet is just information, it can be copied and circulate independently of the underlying debts it supposedly represents. Anyone who has a copy of the spreadsheet can start making high-pressure calls, whether or not they have the right to collect on the debts.

Instead, this is a problem of non-excludability. A buyer of a debt spreadsheet cannot be certain the seller will not turn around and sell it to someone else. Indeed, the seller may have sold it to someone else already. A lender cannot contract for a collection agency’s aid without running the risk that the agency will copy and sell the spreadsheet. Hackers who can get their hands on a spreadsheet, or insiders who can leak one, can monetize it. Borrowers suffer the consequences of unrestricted copying.

Can this problem be fixed by introducing a new intellectual-property right? No, because *that right already exists*. A creditor has the exclusive right to be repaid on a debt. It is fraud to attempt to collect a debt you are not owed, as well as an FDCPA violation. So both the borrower and the actual owner of the debt already have a right against the misuse of

18. Jake Halpern, *Paper Boys*, N.Y. TIMES, Aug. 19, 2014, <https://www.nytimes.com/interactive/2014/08/15/magazine/bad-paper-debt-collector.html>.

a debt spreadsheet that has been severed from the underlying debts. A debt collector who sells a spreadsheet twice commits fraud as well; the hacker who steals a spreadsheet violates the Computer Fraud and Abuse Act. So there is plenty of law on point already.

It is the ease of copying debt spreadsheets that creates the opportunity for abuse, and the ease of copying is a problem inherent to information. In other words, this is the *kind* of problem that IP attempts to solve, but this *particular* problem is not one where IP will work. Keep both of these points in mind as you read the rest of this book.

Problems

Idea Submission Questions

1. If you think Victor Desny should have had some kind of exclusive right to the idea for a movie about Floyd Collins, can you explain why *Desny* should own the idea, rather than Floyd Collins's heirs, or the newspapers who reported the story?
2. Proctor & Gamble, the consumer-goods company that makes products such as Tide laundry detergent and Crest toothpaste, actively encourages idea submission through its Connect + Develop website. But the site's FAQ states, "For your protection and ours, we may decline to review your open innovation submission if it appears to lack intellectual property protection." Why would P&G insist on reviewing only patented ideas?
3. Test yourself: which of the six innovation channels require IP rights? Which of them do not? Are there any that depend on the *absence* of IP rights?
4. How would you advise a debt-collection agency that is considering *buying* a debt portfolio to proceed so as not to fall prey to a double-sale scam? How would you advise a debt-collection agency that is considering *selling* a debt portfolio to proceed, given that the industry is rife with double-sale scammers? How would you advise a consumer who has received a debt-collection call from an agency she has never heard of? Is there a way to reform the industry to prevent these unscrupulous practices?

Bizarro World Problem

This chapter gives a glimpse of a world without IP laws. Suppose that you lived in such a world. A client comes to you with one of the following. How would you advise her to proceed?

- An idea for a movie about a stranded asteroid miner
- A 75,000-word novel about a boy who discovers that he is a wizard

- A new drug for treating heart disease, which will cost \$100 million to test in humans
- An easier-to-hold design for a pipe wrench
- A process for producing pure aluminum from aluminum ore that reduces the cost by 85%
- A catchy song about taking revenge on a cheating boyfriend, recorded in the client's kitchen with lots of background noise
- A recut version of a popular action movie, which takes five minutes off the running time and makes it more suspenseful
- A trading strategy to exploit arbitrage opportunities in the municipal-bond market, which requires \$10 billion in capital to exploit effectively
- A sketch for an elegant off-the-shoulder dress
- The perfect name for a laundromat

In light of your advice, consider what clients like yours will do in a world without IP. Which of these ideas will be shared with the public? Which of them will be created in the first place? Is this world better than ours, or worse?

Lego Problem

The Lego Group encourages fans to submit ideas for new LEGO sets. Fan-submitted ideas are posted to a website, where other fans can vote for their favorites. Ideas receiving 10,000 votes are reviewed by Lego Group employees, and the best ones are reworked for production and sale. Without looking at the Lego Group's actual terms, design a submission process and contractual terms for the idea submission site. Your goals are to attract high-quality submissions that will sell well, to engage LEGO's large and passionate fan community, and to avoid expensive and embarrassing *Desny/Apfel*-style litigation. Consider:

- How, if at all, should the Lego Group compensate users who submit good ideas?
- Who should own the ideas that the Lego Group is interested in developing, to the extent the ideas can be owned at all?
- Who should own the ideas that the Lego Group *isn't* interested in developing?
- What should Lego do about submissions that incorporate third-party material, like vehicles from popular movies?
- What should Lego do about submissions that are copied from other submissions, or from other people's unsubmitted ideas?