

Table of Contents

3 Utility Patent	3
<i>Initial Questions</i>	4
A Subject Matter	5
1 Statutory Subject Matter	5
a Laws of Nature	7
b Mental Processes	9
c Printed Matter	10
d Business Methods	11
<i>Tax Planning Patent Problem</i>	12
<i>Diagnostic Test Problem</i>	13
2 Utility	13
a Specific and Substantial Utility	13
b Moral Utility	14
<i>Sex Sells Problem</i>	16
c Operability	16
B Procedures	17
1 Claims	21
a Claim Drafting	21
b Indefiniteness	24
<i>Freeny v. Apple Inc.</i>	25
<i>Worm Patent Questions</i>	27
2 Disclosure	27
a Enablement	28
<i>Plastic Dye Problem</i>	30
b Written Description	30
c Best Mode	31
<i>Salt Shaker Problem</i>	32
3 Patent Prosecution	32
4 Term	37
C Ownership	37
1 Inventorship	38
<i>Davis Toys Problem</i>	40
2 Priority: Novelty and Statutory Bars	41
a Anticipation	42
b Categories of Prior Art	43
1 "patented"	43
2 "described in a printed publication"	44
3 "in public use"	45

4	"on sale"	50
5	"otherwise available to the public"	51
	<i>Prior Art Questions</i>	51
c	Priority	51
1	Pre-AIA	52
	<i>Morway v. Bondi</i>	53
2	Post-AIA	54
	<i>Pleistocene Park Problem</i>	55
3	Nonobviousness	56
a	Overview	57
b	Combining References	59
	<i>KSR Intern. Co. v. Teleflex Inc.</i>	62
	<i>Beverage Cosy Problem</i>	67
	<i>Battery Problem</i>	67
	<i>KSR Problem</i>	67
c	Analagous Arts	68
D	Infringement: Similarity	69
1	Claim Construction	70
	<i>Thorner v. Sony Computer Entertainment America LLC</i>	71
	<i>Wriggle-No-More Problem</i>	75
2	Literal Infringement	76
	<i>Super Soaker Problem</i>	77
3	Doctrine of Equivalents	78
a	Overview	78
b	Limitations	82
	<i>Amgen Revisited Problem</i>	85
E	Infringement: Prohibited Conduct	85
1	"making, using, offering for sale, or selling"	86
2	Intent	87
3	Proof of Copying	87
F	Secondary Liability	88
1	Attribution and Divided Infringement	88
2	Active Inducement	89
3	Contributory Infringement	93
	<i>Bait Shop Problem</i>	95
G	Defenses	95
1	Invalidity	95
2	Exhaustion	96
	<i>Reusable Camera Problem</i>	99
3	Free Expression	101
4	Prior Use	101
	<i>Sausage Problem</i>	102
5	Experimental Use	102
	<i>Shrimp Deveining Problem</i>	103
	<i>Bizarro World Problem, Redux</i>	103

Utility Patent

Utility patent law protects new and useful inventions.¹ In exchange for fully describing to the public how an invention works, its inventor receives the exclusive right to make, use, and sell it for twenty years. The process of applying for a patent is called *prosecution* or *examination*, and it is administered by the United States Patent and Trademark Office (USPTO or PTO). The mainspring of this system is the *claim*: a precise statement of the technologies over which the inventor asserts rights. The point of of patent prosecution is to generate appropriately clear claim language that covers (or “reads on”) what the inventor actually invented. Patent infringement litigation then compares the patent’s claims with the defendant’s product or process. Claims are interpreted from the perspective of a “*person having ordinary skill in the art*” (or *PHOSITA*), the hypothetical reasonable person of patent law.

Sources of Patent Law

In the United States, patent law derives from Congress’s constitutional power to enact (certain kinds of) IP laws:

The Congress shall have Power ... To promote the Progress of Science and useful Arts, by securing for limited Times to Authors and Inventors the exclusive Right to their respective Writings and Discoveries.²

The first Congress enacted a patent act in 1790. The current patent law is the Patent Act of 1952, as amended, codified as Title 35 of the United States Code. Within living memory, the America Invents Act of 2011, or AIA, significantly modified patent ownership and procedures, so some discussion of both “pre-AIA” and “post-AIA” law is unavoidable.

Although its structure has shifted over time, the modern synthesis of patent law (appropriately enough) is an intricately interlocking doctrinal machine.³ As we will see, patent law uses a handful of basic concepts – e.g., “prior art reference,” “the person of ordinary skill in the art,” and “equivalent” – again and again. The key to understanding patent law is to pay attention to these recurring concepts. The USPTO’s Manual of Patent Examining Procedure (MPEP) is an invaluable refer-

1. The leading patent treatises are DONALD S. CHISUM, *CHISUM ON PATENTS* (2021); R. CARL MOY, *MOY’S WALKER ON PATENTS* (2021); ROBERT C. FABER, *FABER ON MECHANICS OF PATENT CLAIM DRAFTING* (2021).



2. UNITED STATES CONSTITUTION art. I § 8 cl. 8 (1789).
3. “Looking at these cases is much like looking at a wonderful machine. But, of course, when looking at a beautiful piece of machinery that functions like a clock or like clockwork, the next question might be whether this wonderful precision instrument bears any relation to reality.” Dan L. Burk, *Biotechnology in the Federal Circuit: A Clockwork Lemon*, 46 ARIZ. L. REV. 441 (2004).

ence for these, and on many other points of patent law and procedure.⁴

Since 1982, appeals in patent cases have been funneled through the Court of Appeals for the Federal Circuit.⁵ Judges on the Federal Circuit are often appointed for their expertise in technology and patent law, and the court has developed an extensive body of patent caselaw. When researching a patent issue, pay close attention to what the Federal Circuit (and its predecessor court, the Court of Customs and Patent Appeals, or CCPA) has held.

Justifications for Patent Law

Why patent law?⁶ Three stories are usually advanced, the first two of which should be familiar from trade secret law

- Patent law serves an **innovation** function by giving incentives that enable investors to recoup their investment.
- It serves a **contracting** function by enabling inventors to commercialize their inventions without fear of being ripped off by business partners or imitated by competitors.
- It serves a **disclosure** function by requiring inventors to make public significant information about how their inventions work.

It is this third basis, with its emphasis on widespread sharing of the details of inventions, that gives patent law its distinctive character.

Patent Law and Trade Secret Law

Utility patent law is the yang to trade secret's yin. Where trade secret law keeps information shaded and hidden, patent law brings information out into open daylight. Where trade secret law is primarily state law with a thin federal overlay, patent law is almost exclusively federal.

But if patent and trade secret are polar opposites, they are also deeply interdependent. Patent law's public disclosure requirements make sense only against a backdrop in which secrecy is possible and undesirable. The timing of patentability, the allocation of ownership, and the eligibility of an invention for a patent at all are based on a presumption that inventors will keep their work secret until it is time to apply for a patent. For businesses, trade secret and patent are complementary strategies that often work hand-in-glove.

Initial Questions

1. Recall *Apfel v. Prudential-Bache Securities, Inc.*, the municipal-bond negotiation case. How would the negotiations have gone if Apfel and his business partner had held a patent?
2. Your client has a patent application pending for a new chemical formulation for a coating to make smartphone display glass more smudge-resistant. You estimate that there is an 80% chance that it will be granted and a patent will issue. How should your client approach negotiations with potential investors? Buyers?

4. U.S. PAT. & TRADEMARK OFF., MANUAL OF PATENT EXAMINATION PROCEDURE (2020) [hereinafter MPEP]. Fair warning: the courts have not always agreed with the USPTO's interpretations.

5. The Federal Circuit's specialized docket also includes veterans' cases, monetary claims against the United States government, and some civil-service-protection cases.

6. "No economist, on the basis of present knowledge, could possibly state with certainty that the patent system, as it now operates, confers a net benefit or a net loss upon society. If we did not have a patent system, it would be irresponsible, on the basis of our present knowledge of its economic consequences, to recommend instituting one. But since we have had a patent system for a long time, it would be irresponsible, on the basis of our current knowledge, to recommend abolishing it." FRITZ MACHLUP, AN ECONOMIC REVIEW OF THE PATENT SYSTEM (1958).

3. You work for a bicycle manufacturer and have been approached by an inventor claiming to hold a patent on an improved arrangement of bicycle spokes that will reduce vibrations, who is interested in licensing the technology to you. How should you respond?
4. Recall Moe, the inventor of the Flaming Moe. Would Moe be better off trying to patent the formula for the Flaming Moe? Would society be better off if he did?
5. Trade secret law worries about preventing arms races between inventors trying to keep their inventions secret and imitators trying to steal the details of those inventions. Is this an important policy concern for patent law?

A Subject Matter

Section 101 of the Patent Act succinctly describes what kinds of inventions are eligible to be patented:

Whoever invents or discovers any new and useful process, machine, manufacture, or composition of matter, or any new and useful improvement thereof, may obtain a patent therefor, subject to the conditions and requirements of this title.⁷

7. 35 U.S.C. § 101.

As interpreted by the courts, Section 101 imposes two conditions on patentability: statutory subject matter and utility.

1 Statutory Subject Matter

It is customary to divide the world of things that can be patented into two categories: *products* and *processes*. A product can be a “machine, manufacture, or composition of matter,” a definition that includes mechanical, electrical, and electronic devices; chemical compounds; biological organisms; objects with useful shapes; and all manner of tangible things. A process is

an act, or a series of acts or steps. A process is a mode of treatment of certain materials to produce a given result. It is an act, or a series of acts, performed upon the subject-matter to be transformed and reduced to a different state or thing.⁸

8. MPEP, *supra* note 4, § 2106.

Thus, a patent can cover a tangible thing, like a system of gears, or it can cover an intangible process, like a method for removing impurities from aviation fuel. It can even cover both, but at any given moment – i.e., in any given claim – it covers one or the other. In addition, because Section 101 includes “any new and useful improvement thereof,” improvements to already-existing things are patentable subject matter. These can consist of combining old things with other old things, or new uses of old things. The resulting patent is unsurprisingly called an *improvement patent*.

This is an extremely wide scope. There is no field of technology and engineering that is left out. “Congress intended statutory subject matter to include anything under the sun that is made by man.”⁹

So much for what can be patented. Now for what cannot.

First, patent law excludes anything that already exists. The use of the word “discovers” in Section 101 suggests that finding a thing, rather than creating it, is enough to qualify for a patent. But this is not the case. An invention must be “new,” so only things “made by man” are patentable. “Thus, a new mineral discovered in the earth or a new plant found in the wild is not patentable subject matter.”¹⁰ In *Diamond v. Chakrabarty*, the Supreme Court considered a microorganism that had been genetically modified to enhance its natural ability to break down crude oil:

[T]he patentee has produced a new bacterium with markedly different characteristics from any found in nature and one having the potential for significant utility. His discovery is not nature’s handiwork, but his own; accordingly it is patentable subject matter under § 101.¹¹

Second, there are a few specific exclusions. One is for **nuclear weapons**: “No patent shall hereafter be granted for any invention or discovery which is useful solely in the utilization of special nuclear material or atomic energy in an atomic weapon.”¹² Another is for **human beings**. “Notwithstanding any other provision of law, no patent may issue on a claim directed to or encompassing a human organism.”¹³ In other words, one of the worst things in the world (nuclear weapons) and one of the best things in the world (people) are both unpatentable.

Third, The Supreme Court has interpreted the phrase “invents or discovers” as excluding “laws of nature, physical phenomena, and abstract ideas.”¹⁴ This one requires more discussion. Justice Thomas’s opinion for the Supreme Court in *Alice Corp. v. CLS Bank Int’l*, decided in 2014, gives the standard test for abstract ideas:

First, we determine whether the claims at issue are directed to one of those patent-ineligible concepts. If so, we then ask, what else is there in the claims before us? To answer that question, we consider the elements of each claim both individually and as an ordered combination to determine whether the additional elements transform the nature of the claim into a patent-eligible application. We have described step two of this analysis as a search for an “inventive concept” — i.e., an element or combination of elements that is sufficient to ensure that the patent in practice amounts to significantly more than a patent upon the ineligible concept itself.¹⁵

This test has become known as the “*Alice* two-step.” In practice, almost any invention is in some sense based on laws of nature and other abstract ideas, so *Alice* step one is always satisfied and almost all of the action is

9. *Diamond v. Chakrabarty*, 447 U.S. 303, 309 (1980) (internal quotation omitted).

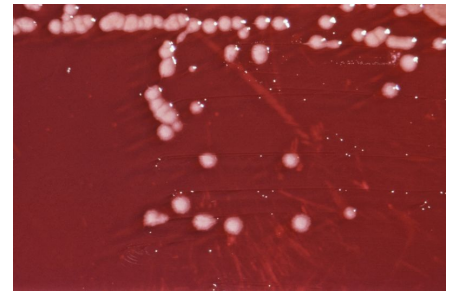

A *Pseudomonas* bacterium from the same genus as the one at issue in *Chakrabarty*.

10. *Id.*

11. *Id.* at 310.

12. 42 U.S.C. § 2181(a).

13. Leahy–Smith America Invents Act (AIA), Pub. L. No. 112-29, § 33(a), 125 STAT. 284, 340 (2011).

14. *Diamond*, 447 U.S. at 309.

15. *Alice Corp. v. CLS Bank Int’l*, 134 S. Ct. 2347, 2355 (2014) (internal quotation omitted).

at the second step.

a Laws of Nature

The caselaw is full of statements like, “Einstein could not patent his celebrated law that $E = mc^2$; nor could Newton have patented the law of gravity.”¹⁶ But what would a patent on Newton’s law of universal gravitation even look like? Objects are attracted to each other with a force proportional to the product of their masses and inversely proportional to the distance between them, regardless of what anyone does about it. No one has any control over whether they obey Newton’s law of gravity or not, and the patent system has no hope of enjoining a defendant from obeying it. Nor does the law prevent people from writing about the law of gravity, or using Einstein’s equation to do calculations. That’s not the kind of thing that patent law ever does, for any kind of patent. And any claim that covered the use of the physical laws of nature would be blatantly non-novel; nature has already been following those laws for billions of years.

At the same time, the abstract-idea exclusion cannot be read too literally, because *all* patents are based on laws of nature. The first Bell Labs transistor patent (No. **2,502,488**), the foundation of the entire computer industry, was based on the laws of electromagnetism and the physics of silicon-based materials with very slight impurities. The technology underlying every invention works at all because of laws of nature, which its inventors have recognized and applied.

Instead, the modern focus in the *Alice* two-step is on *preemption*: does a claim that involves an abstract idea “integrate the building blocks into something more,” so that it leaves other applications of the idea free for others to use?¹⁷ Thus, for example, “Archimedes [could not have] secured a patent for his famous principle of flotation by claiming a process consisting of simply telling boat builders to refer to that principle in order to determine whether an object will float.”¹⁸

A good example of this is approach is *Mayo Collaborative v. Prometheus Labs*. The patent there involved thiopurine drugs, a class of drugs used to treat autoimmune diseases like Crohn’s disease.¹⁹ Because biochemistry, people’s bodies respond differently to these drugs, and “it has been difficult for doctors to determine whether for a particular patient a given dose is too high, risking harmful side effects, or too low, and so likely ineffective.”²⁰ Simplifying slightly, when a patient takes one of these drugs, their body starts to process it, causing a group of chemicals referred to as 6-TG to form in their bloodstream.²¹ The patentees worked out a relationship between a patient’s 6-TG levels and the likely effects of a thiopurine drug.

More specifically, the patents – U.S. Patent No. **6,355,623** and U.S. Patent No. **6,680,302** – embody findings that concentrations in a patient’s blood of 6-TG [above 400 picomoles per 8×10^8 red blood cells] indicate that the dosage is likely too high for the patient, while concentrations in the blood of 6-

16. *Diamond*, 447 U.S. at 309.

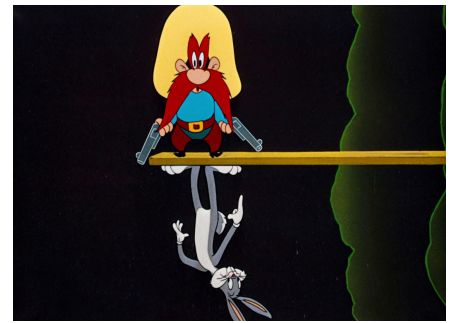

Bugs Bunny: “I know this defies the law of gravity, but you see I never studied law.” (*High-Diving Hare* (1948))

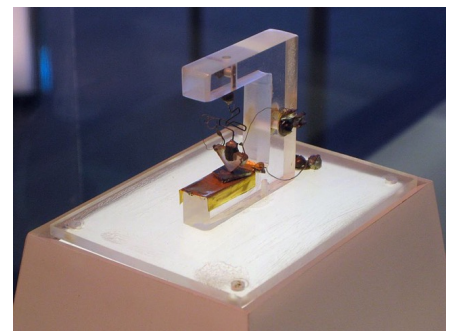

The first transistor, constructed in 1947.

17. *Alice*, 134 S. Ct. at 2354.

18. *Mayo Collaborative v. Prometheus Labs*, 566 U.S. 66, 78 (2012). Archimedes’s principle is that the buoyant force on an object in a liquid is equal to the weight of the liquid it displaces. Thus, objects that are denser than water sink, and objects that are less dense than water float.



A page from the earliest surviving manuscript (produced ca. 530 AD) of Archimedes’s *On Floating Bodies* (published ca. 250 BC).

19. *Id.*

20. *Id.* at 73.

21. Short for 6-thioguanine and its nucleotides.

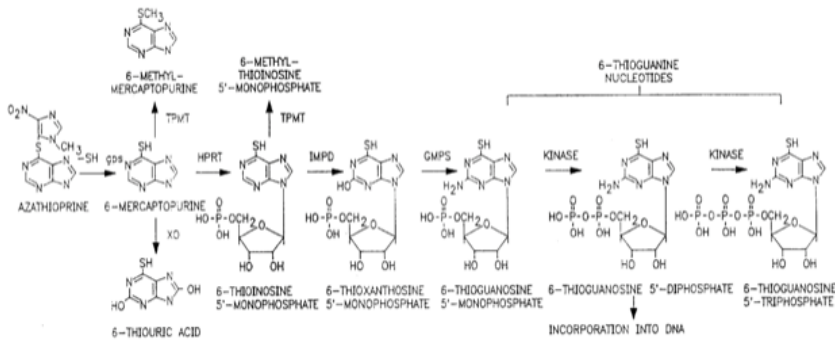

Diagram from U.S. Pat. No. 6,680,302 of metabolic pathways leading to 6-TG compounds

TG metabolite [below 230 picomoles per 8×10^8 red blood cells] indicate that the dosage is likely too low to be effective.²²

22. *Mayo*, 566 U.S. at 74.

Claim 1 of the 623 Patent described a process based on this relationship:

A method of optimizing therapeutic efficacy for treatment of an immune-mediated gastrointestinal disorder, comprising:

- (a) administering a drug providing 6-thioguanine to a subject having said immune-mediated gastrointestinal disorder; and
- (b) determining the level of 6-thioguanine in said subject having said immune-mediated gastrointestinal disorder,

wherein the level of 6-thioguanine less than about 230 pmol per 8×10^8 red blood cells indicates a need to increase the amount of said drug subsequently administered to said subject and

wherein the level of 6-thioguanine greater than about 400 pmol per 8×10^8 red blood cells indicates a need to decrease the amount of said drug subsequently administered to said subject."

The plaintiff Prometheus, the exclusive licensee of these patents, sold 6-TG diagnostic tests. The Mayo Clinic and its laboratory used and sold its own 6-TG diagnostic test. Prometheus sued.

Justice Breyer's opinion for the Supreme Court held that this was an unpatentable law of nature, based on a close reading of the claim.

First, the "administering" step simply refers to the relevant audience, namely doctors who treat patients with certain diseases with thiopurine drugs. That audience is a pre-existing audience; doctors used thiopurine drugs to treat

patients suffering from autoimmune disorders long before anyone asserted these claims. In any event, the prohibition against patenting abstract ideas cannot be circumvented by attempting to limit the use of the formula to a particular technological environment.

Second, the “wherein” clauses simply tell a doctor about the relevant natural laws, at most adding a suggestion that he should take those laws into account when treating his patient. . . .

Third, the “determining” step tells the doctor to determine the level of the relevant metabolites in the blood, through whatever process the doctor or the laboratory wishes to use. As the patents state, methods for determining metabolite levels were well known in the art. . . . Thus, this step tells doctors to engage in well-understood, routine, conventional activity previously engaged in by scientists who work in the field. . . . The prohibition against patenting abstract ideas cannot be circumvented by adding insignificant post-solution activity.²³

Fourth, to consider the three steps as an ordered combination adds nothing to the laws of nature that is not already present when the steps are considered separately. Anyone who wants to make use of these laws must first administer a thiopurine drug and measure the resulting metabolite concentrations, and so the combination amounts to nothing significantly more than an instruction to doctors to apply the applicable laws when treating their patients.

Claim 1 is invalid because it preempts the field of 6-TG-based diagnostic tests. Restricted to specific diagnostic tests, or to particular changes in treatment based on their results, it might have been valid. (Or not: it might have failed for other reasons.) But instead the patent’s drafters shot for the moon and made the claim’s only difference from the prior art the correlations recited in the “wherein” step. Those correlations are clinically actionable – this is the entire point of the research program that led to their discovery – but Claim 1 does not claim any particular clinical action, only the abstract “indicat[ion]” of a “need” to change thiopurine-drug dosage. It thereby lays claim to all such clinical actions, now known or yet to be devised.

b Mental Processes

There is a longstanding rule – so fundamental that it is rarely spelled out as such – that *mental processes* are not patentable.²⁴ “[I]nventions directed to human thinking – that seek to generate or anticipate a human mental response – are ineligible subject matter.”²⁵ This is the most fundamental reason why the liberal arts like music, poetry, and history are unpatentable. They “merely produce a desired state of mind.”²⁶

Attempts to patent mental processes as such are quite rare. Instead,

23. “A patent lawyer walks into a barber shop. The barber takes a look at the lawyer for a bit, and then says, ‘Ok, that’ll be \$20.’ The lawyer responds, ‘But you didn’t cut my hair!’ The barber replies, ‘That’s insignificant post-solution activity.’” Michael S. Kwun, *Alice Tells a Joke*, 19 GREEN BAG 2D 329 (2016). Unfair?

24. Other patent systems make this limitation explicit. A European patent must be “susceptible of industrial application.” Convention on the Grant of European Patents, §§ 52, 57, 1977.

25. Joseph Matal, *The Three Types of Abstract Ideas*, 30 FED. CIR. BAR J. 87, 153 (2021).

26. *In re Yuan*, 188 F.2d 377, 381 (CCPA 1951).

a typical claim involves some device that exists outside of the human mind or some process with physical steps that take place outside of the human mind. These claims are fine as long as the device or process would be proper subject matter without a human in the picture. So, for example, a new arrangement of explosives for a firework might be *useful* because people will think that resulting display is pretty, because the arrangement of explosives is not a mental process.

In other words, the inclusion of mental steps in a claim doesn't automatically *disqualify* the claim from being patentable. Instead, those steps are *disregarded* when considering the patentability of the claim. If the only new aspect of the firework is that observers will see it and believe that it is pretty, then the arrangement of explosives is unpatentable because it is not novel.

Similarly, it is fine to have a human in the loop as long as the human actually *does something* as a result, such as comparing two immunization schedules and then administering the lower-risk one.²⁷ The mental step of comparing the immunization schedules is still unpatentable subject matter. But what the human does as a result is different depending on the results of the comparison, and that is what is being claimed, and it is proper subject matter.²⁸

c Printed Matter

A closely related rule is the *printed matter* doctrine that "any information claimed for its communicative content" is patent-ineligible.²⁹ Applications of information may be patentable, and ways of recording and conveying it may be patentable. But information itself, whose value consists in getting people to learn from and think about it, is not patentable. The doctrine started with cases literally involving pieces of paper with things printed on them, such as *In re Reeves*, where the applicant claimed a chart with checklists for valuing buildings,³⁰ and *In re Russell*, where the applicant claimed a directory with names arranged phonetically,³¹ but "has evolved over time to guard against attempts to monopolize the conveyance of information using any medium."³²

As with mental processes, the inclusion of printed matter does automatically not render an invention unpatentable. Printed matter is proper subject matter when it is "functionally related" to the substrate it is printed on.³³ So in *In re Miller*, the printed markings were numbers on a measuring cup to make it easier for cooks to prepare a half or third of a recipe.³⁴ The printed markings did not change how the measurement cup itself worked, but a cook would select and use a cup differently based on the markings. But a component on an implantable medical access port indicating its flow rate was not functionally related because "mere marking of products . . . with information concerning the product, does not create a functional relationship."³⁵

27. *Classen Immunotherapies, Inc. v. Biogen IDEC*, 659 F.3d 1057 (Fed. Cir. 2011).
28. Can you see a way to put the holding in *Mayo* in terms of the mental-process exclusion?
29. *C.R. Bard, Inc. v. Angiodynamics, Inc.*, 979 F.3d 1372, 1381 (Fed. Cir. 2020).
30. *In re Reeves*, 62 F.2d 199 (CCPA 1932).
31. *In re Russell*, 48 F.2d 668 (CCPA 1931).
32. *Angiodynamics*, 979 F.3d at 1381.
33. *Id.*

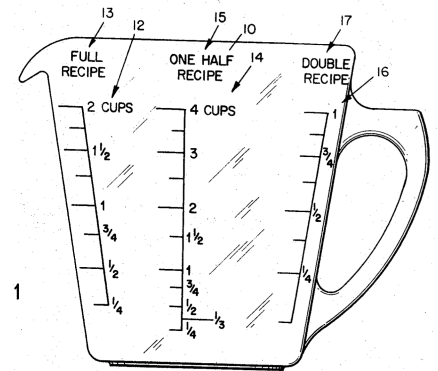

U.S. Pat. No 3,530,722: Recipe measuring device

34. *In re Miller*, 418 F.2d 1392 (CCPA 1969).

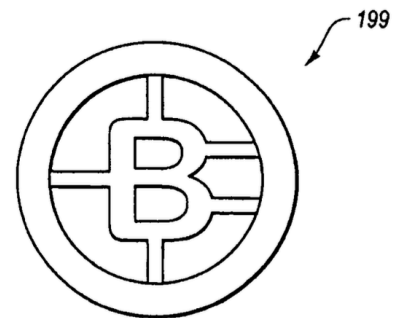

U.S. Pat. No 8,475,417: Assemblies for identifying a power injectable access port

35. *Angiodynamics*, 979 F.3d at 1382.

d Business Methods

By the late 1990s, the Federal Circuit had talked itself into an extremely broad view of patentable subject matter. For example, in *State Street Bank & Trust Co. v. Signature Financial Group*, it held that a “system that allows an administrator to monitor and record the financial information flow and make all calculations necessary for several mutual funds to pool their investment funds into a single portfolio” was proper subject matter because it yielded a “a useful, concrete and tangible result.”³⁶

This was, in the view of some, a *business-method patent*: it prevented competing administrators from pooling mutual funds in the same way. Critics argued that business-method patents were problematic, because business-method patents could lock up an entire business model, taking patents too far from their technological roots and suppressing normal marketplace competition. Defenders argued that business-method patents supported valuable innovation, and besides, there was nothing in the Patent Act specifically excluding them.

Facing criticism about the scope and clarity of its patentable subject matter caselaw, the Federal Circuit took the case of *Bilski v. Kappos* an *en banc* case in 2008. Bernard Bilski and Rand Warsaw filed an application claiming a method of “managing the consumption risk costs of a commodity” by selling to consumers at fixed price and buying from providers at another fixed price.³⁷ For example, a broker could make contracts to buy coal from mines at \$30 per ton and contracts to sell coal to power plants at \$32 per ton, protecting the mines from the risk of sudden drops in the price of coal, and protecting the power plants from the risk of sudden spikes in the price of coal.

The court held that a process was proper subject matter if “(1) it is tied to a particular machine or apparatus, or (2) it transforms a particular article into a different state or thing.”³⁸ Under this *machine-or-transformation test*, Bilski and Warsaw’s claim was directed to an abstract idea:

Purported transformations or manipulations simply of public or private legal obligations or relationships, business risks, or other such abstractions cannot meet the test . . . claim 1 does not involve the transformation of any physical object or substance, or an electronic signal representative of any physical object or substance.³⁹

As that last sentence hints, the machine-or-transformation test, despite seemingly excluding business methods, had a giant loophole. Instead of claiming an abstract business method for hedging transactions in commodities like coal, an inventor could claim the physical effects of the method in the world (e.g., delivering physical shipments of coal), or claim the physical implementation of the business logic (e.g., a computer system storing database records about coal purchases). Even this wasn’t enough for three dissenting judges, who accused the majority of “impos[ing] a new and far-reaching restriction on the kinds of inventions

36. *State St. Bank & Tr. Co. v. Signature Fin. Grp.*, 149 F.3d 1368, 1371, 1373 (Fed. Cir. 1998).

37. *Bilski v. Kappos*, 561 U.S. 593, 615 (2010).



The Wolf of Wall Street (2013)

38. *In re Bilski*, 545 F.3d 943, 954 (Fed. Cir. 2008).

39. *Id.* at 963–64.

that are eligible to participate in the patent system.”⁴⁰

In 2010, the Supreme Court agreed with the Federal Circuit’s that the hedging claim was an abstract idea, but with fundamentally different reasoning.

- First, the Supreme Court narrowly held that there was no categorical rule against business-method patents as such.⁴¹ Four Justices disagreed and would have held that “a series of steps for conducting business” was unpatentable *per se* because it was not a “process.”⁴²
- Second, the Court thoroughly repudiated the Federal Circuit’s focus on physical things. While the machine-or-transformation test was “a useful and important clue, an investigative tool,”⁴³ it “was not intended to be an exhaustive or exclusive test.”⁴⁴
- Third, the Court focused on the idea that a patent for an abstract idea could preempt too much future innovation. “Allowing petitioners to patent risk hedging would pre-empt use of this approach in all fields, and would effectively grant a monopoly over an abstract idea.”⁴⁵ Other claims were “broad examples of how hedging can be used in commodities and energy markets,”⁴⁶ but “limiting an abstract idea to one field of use or adding token post-solution components [does] not make the concept patentable.”⁴⁷

Despite *Bilski*’s insistence that there is no *per se* rule against business-method patents, subsequent caselaw has been extremely hostile to financial-engineering patents like the ones in *State Street Bank & Trust* and *Bilski*. The Federal Circuit has invalidated patents on “a system of paying for remote purchases at a local store,” “using statistical sampling to predict the behavior of financial markets,” “an automated system for processing car loans through a clearinghouse,” and “notifying a user that spending has reached budget limits,” among many others.⁴⁸ So the dissenters may have effectively won the day; business methods are almost impossible to patent as such.

Alice stands for the proposition that an otherwise-ineligible business method cannot be turned into a patentable process simply by doing it on a computer. The case involved a patent on a system for reducing settlement risk in a financial transaction, i.e., “the risk that only one party to an agreed-upon financial exchange will satisfy its obligation.”⁴⁹ The Supreme Court held that it was unpatentable because the claims “simply instruct[ed] the practitioner to implement the abstract idea of intermediated settlement on a generic computer.”⁵⁰

Tax Planning Patent Problem

You are staff counsel to Representative Helvering (R-IA), who has read a number of newspaper articles on the growing phenomenon of “tax planning patents.” These patents describe transactions designed to help a company reduce the taxes it owes. For example, one such patent describes dividing a real estate portfolio into a number of shares held as

40. *Id.* at 976 (Newman, J. dissenting). Based on the printed-matter and mental-steps caselaw, doesn’t she have a point?

41. Indeed, some of the earliest U.S. patents involved what would today be called business methods. Patent X4,610, for example, was directed to “a detailed lottery system, including different ways to number tickets, and the order of determining winners and giving prizes.” Michael Risch, *America’s First Patents*, 64 FLA. L. REV. 1281, 1322 (2012).

42. *Bilski*, 561 U.S. at 3232 (Stevens, J. concurring in the judgment).

43. *Id.* at 3227.

44. *Id.* at 3226.

45. *Id.* at 3231.

46. *Id.*

47. *Id.*

48. *Matal*, *supra* note 25, at 103–07.

49. *Alice Corp. v. CLS Bank Int’l*, 134 S. Ct. 2347, 2352 (2014).

50. *Id.* at 2359.

tenancies in common subject to a master lease, in which each holder receives guaranteed annual income and is subject to repurchase at fair market value at a specified date, such that the investments qualify for tax-deferred treatment under ... you get the picture.

The Representative has asked you to help her think through the policy and legal issues these patents raise. She wants to know whether they are valid under current law and whether they're contributing to tax evasion. If they're problematic, she would like your suggestions on possible legislative fixes (either to the Patent Act or to the Internal Revenue Code).

Section 14(a) of the America Invents Act reads, "For purposes of evaluating an invention under section 102 [novelty] or 103 [nonobviousness], any strategy for reducing, avoiding, or deferring tax liability, whether known or unknown at the time of the invention or application for patent, shall be deemed insufficient to differentiate a claimed invention from the prior art." What do you think of this solution?

Diagnostic Test Problem

Your client, Biomarker Industries, is a major medical-device manufacturer and testing laboratory. It is considering creating a new testing kit for thiopurine drug effectiveness based on the 6-TG pathway at issue in *Mayo*, to be sold in bulk to hospitals. As part of the development process, Biomarker's research staff will conduct studies on the correlations of various other metabolites (see the diagram on page 8) and may discover new correlations. Advise Biomarker on the patent issues involved, including any infringement risks it may face, and its own ability to use patent law to protect its own innovations.

2 Utility

The utility requirement derives from the phrase "new and useful" in Section 101. If an invention has one use – even one – it satisfies the utility requirement and the patentee can claim any and all uses.⁵¹ An earring, a guitar rest for finger tapping, and a method for making a cat chase a laser pointer all easily pass the utility threshold.

a Specific and Substantial Utility

This expansiveness opens up a distinctive risk, however. Suppose that an inventor is developing a new battery for electric vehicles, but the prototypes keep bursting into flames. Undeterred, the inventor files a patent application anyway. When the USPTO objects that the design lacks utility, the inventor replies that it is useful as an incendiary device for starting fires. The problem, from a public-policy perspective, is that they have cut in line ahead of other inventors who are diligently working on similar battery designs, rewarding unproductive initial tinkering rather than the inventive work needed to make a functional battery.

Thus, the USPTO requires that an invention have "specific and substantial" utility; it will reject "throwaway" utilities like using "a complex

51. MPEP, *supra* note 4, § 2107 ("An applicant need only provide one credible assertion of specific and substantial utility for each claimed invention to satisfy the utility requirement.").

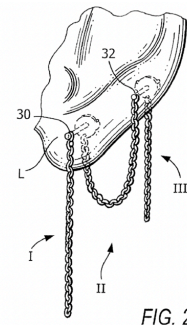

U.S. Pat. No. 7,520,144: Single Earring Set for Double Pierced Ears

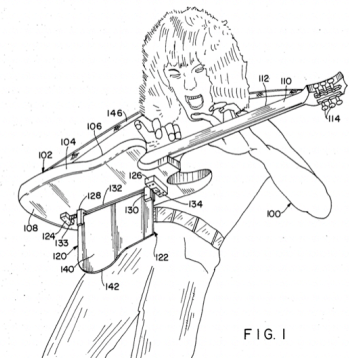

U.S. Pat. No. 4,656,917: Musical Instrument Support

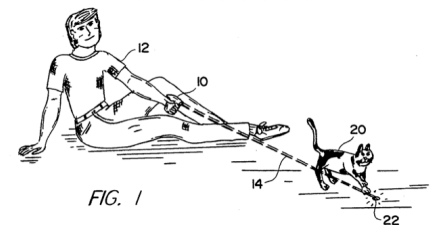

U.S. Pat. No. 5,443,036: Method of Exercising a Cat

invention as landfill.”⁵² A specific utility is one that “provide[s] a well-defined and particular benefit to the public.”⁵³

This requirement has the most bite in the biological sciences, where the testing process can be lengthy. In *Brenner v. Manson*, the Supreme Court held that a process for making certain chemicals called 2-methyl-dihydrotestosterones lacked utility.⁵⁴ The process worked, in the sense that it produced the chemicals. But the chemicals themselves did not have a known utility. A similar chemical had been shown to inhibit tumors in mice, but there was also undisputed evidence that “minor changes in the structure of a steroid may produce profound changes in its biological activity.”⁵⁵ The result of this doctrine is to require inventors in the biological sciences and other unpredictable arts to apply for patents *later*, once they have more evidence that their specific product has a real-world use. The MPEP contrasts “a therapeutic method of treating a known or newly discovered disease” (useful) and “[a]n assay that measures the presence of a material which has a stated correlation to a predisposition to the onset of a particular disease condition” (useful) with “[b]asic research such as studying the properties of the claimed product itself or the mechanisms in which the material is involved” (not useful).⁵⁶

b Moral Utility

At one time, the doctrine of *moral utility* excluded from patentability inventions that are “injurious to the well-being, good policy, or sound morals of society.”⁵⁷ In *Lowell v. Lewis* in 1817, Justice Story gave examples: “a new invention to poison people, or to promote debauchery, or to facilitate private assassination.”⁵⁸ One line of inventions “to promote debauchery” consisted of gambling devices: e.g., in *National Automatic Device Co. v. Lloyd*, the court invalidated as immoral a patent on an “Automatic Race-Course” because its only known use was “to place them in saloons, bar-rooms, and other drinking places, where the frequenters of such places make wagers as to which of the toy horses will stop first.”⁵⁹ Another consisted of sexual devices, which were illegal under many states’ anti-obscenity “Comstock laws.” And a third consisted of inventions that were in some way deceptive: e.g., a seamless stocking knit so that it had a line up the back resembling the seam in a (more expensive) fully-fashioned stocking.⁶⁰

Over the course of the 20th century, all of these moral objections dropped away. Legalized gambling made it hard to say with a straight face that a gambling device was inherently immoral – and there was a substantial, heavily regulated industry eager to purchase improved slot machines. Most states have struck down or repealed their laws against sex toys, and legal culture is far less hostile to sexual pleasure.

The story of deceptive patents is the most interesting, because it was the last domino to fall. In the 1999 case of *Juicy Whip, Inc. v. Orange Bang, Inc.*, the Federal Circuit held that making one thing look like another thing that it is not counts as a valid utility. The case concerned a patent

52. *Id.*

53. *In re Fisher*, 421 F.3d 1365, 1371 (Fed. Cir. 2005).

54. *Brenner v. Manson*, 383 U.S. 519 (1966).

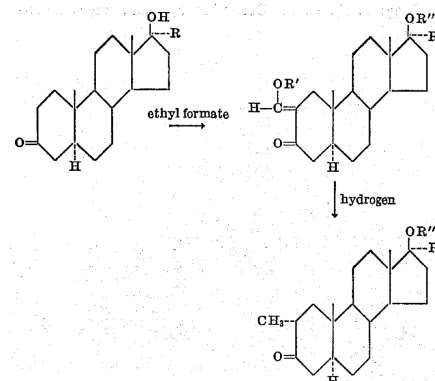

U.S. Pat. No. 2,908,693: Process for the Production of 2-methyl-dihydrotestosterones

55. *Id.* at 532 n.19.

56. MPEP, *supra* note 4, § 2107.01.

57. *Lowell v. Lewis*, 15 F. Cas. 1018, 1019 (C.C.D. Mass. 1817).

58. *Id.*

59. *Nat'l Automatic Device Co. v. Lloyd*, 40 F. 89, 89–90 (N.D. Ill. 1889).

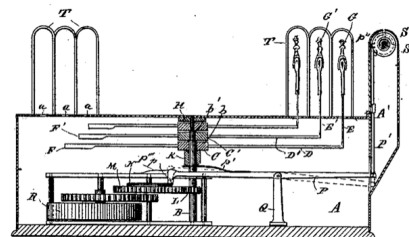

U.S. Pat. No. 410,981: Automatic Race Course

60. *Scott & Williams v. Aristo Hosiery Co.*, 7 F.2d 1003 (2d Cir. 1925).

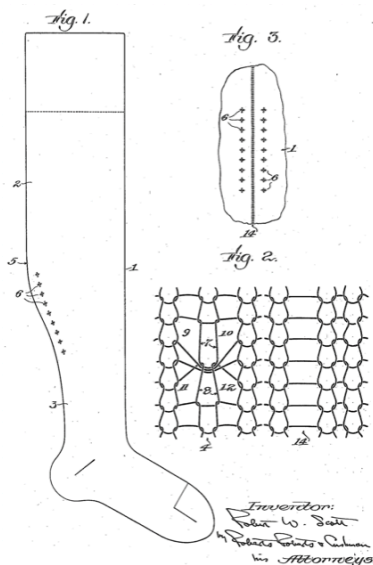

(a) U.S. Pat. No. 1,233,714: Seamless Stocking

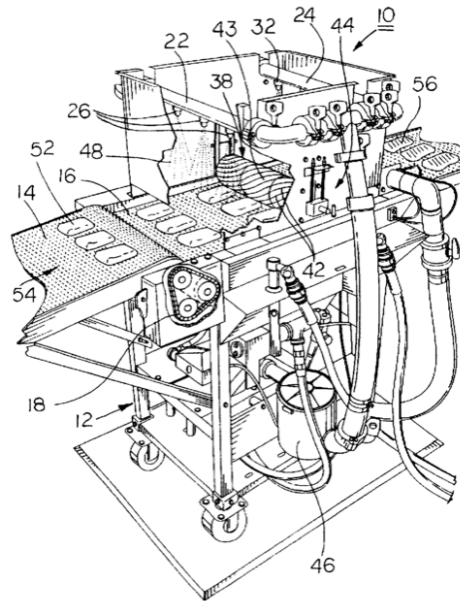

(b) U.S. Pat. No. 5,762,968: Method and Apparatus for Producing Imitation Grill Marks on Food Without Using Heat

Juicy Whip claiming “a post-mix beverage dispenser that is designed to look like a pre-mix beverage dispenser.”⁶¹ In a “post-mix” dispenser, the various ingredients (e.g. soda syrup, water, and carbonation) are combined only when the drink is being poured, but in a pre-mix” dispenser, a clear container on top holds the soda or slurpee that is dispensed through a spout below, so that people can see the drink before they buy it. A pre-mix dispenser is more appealing to consumers, but but bacteria can build up in the container, so it must be cleaned often. In the claimed invention, the container on top contains “a fluid that simulates the appearance of the dispensed beverage and is resistant to bacterial growth”; although the actual drink comes from a hidden series of tubes inside the machine, the machine “create[s] the visual impression that the [container] is the principal source of the dispensed beverage.”⁶²

The defendants argued, and convinced the trial judge, that this invention “lacked utility because its purpose was to increase sales by deception,”⁶³ i.e., by tricking consumers into thinking they were getting a drink from the container when they weren’t. But the Federal Circuit disagreed, repudiating the older deceptive-use cases and holding, “The fact that one product can be altered to make it look like another is in itself a specific benefit sufficient to satisfy the statutory requirement of utility.”⁶⁴ The invention does *something*, and whether that something is good or bad for those fortunate or unfortunate enough to be exposed to it is irrelevant.

The requirement of “utility” in patent law is not a directive to the Patent and Trademark Office or the courts to serve as arbiters of deceptive trade practices. Other agencies, such as

61. Juicy Whip, Inc. v. Orange Bang, Inc., 185 F.3d 1364, 1365 (Fed. Cir. 1999).

U.S. Patent Nov. 15, 1996 Sheet 1 of 3 5,575,405

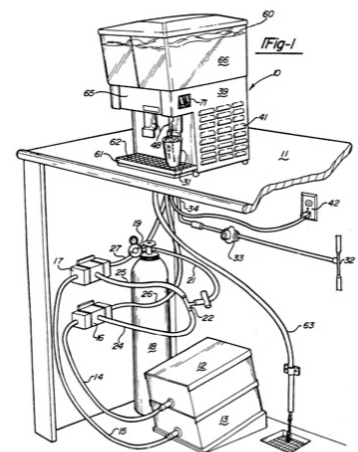

U.S. Patent No. 5,575,405: Post-Mix Beverage Dispenser With an Associated Simulated Display of Beverage

62. *Id.*

63. *Id.* at 1366.

64. *Id.* at 1367.

the Federal Trade Commission and the Food and Drug Administration, are assigned the task of protecting consumers from fraud and deception in the sale of food products.

This view of the USPTO’s remit echoes a distinctively late 20th-century view of the role of courts: they are not in the business of deciding what is good or bad, moral or immoral. Patents protect the patentee’s *private* exclusive right to keep others from making and using the invention. They do not enforce *public* values like food safety or consumer rights.

As *Webber v. Virginia*’s reference to “deadly poison” suggests, nothing now remains of Justice Story’s categories of supposedly immoral inventions. Indeed, it is hard to think of any inventions whose uses are categorically immoral. An “invention to poison people” can be repackaged and sold as rodenticide. One inventor’s “device to facilitate private assassination” is another’s federally contracted orbital military laser. Or take Juicy Whip’s drink machine. The defendants argued that its use was to make a post-mix machine fraudulently imitate a pre-mix one. But an equally plausible way of describing it is that it was useful for making a pre-mix machine safer by reducing the risk of bacterial contamination. That is an eminently moral use.

Sex Sells Problem

The year is 1930. Your client manufactures and sells devices for personal sexual gratification. Competitors have begun producing inferior knock-off versions of some of its best-selling products. Advise your client on whether and how it should seek patent protection.

c Operability

A rarely invoked restriction on utility is that the USPTO will reject inventions that it thinks are inoperable, i.e. “totally incapable of achieving a useful result.”⁶⁵ It invokes this rule mostly in cases when the asserted utility is scientifically implausible.

Examples of such cases include: an invention asserted to change the taste of food using a magnetic field, a perpetual motion machine, a flying machine operating on “flapping or flutter function,” a “cold fusion” process for producing energy, a method for increasing the energy output of fossil fuels upon combustion through exposure to a magnetic field, uncharacterized compositions for curing a wide array of cancers, and a method of controlling the aging process.⁶⁶

In *Newman v. Quigg*, the USPTO ordered the inventor of a purported perpetual-motion machine to produce a model for testing by the National Bureau of Standards. **It failed**, and the USPTO rejected his application. But sometimes the USPTO issues a patent whose utility is extremely unlikely, such as one for a spaceship “able to move at speeds substantially higher than the light speed in the ambient space.” Does it

- 65. *Brooktree Corp. v. Advanced Micro Devices, Inc.*, 977 F.2d 1555,(Fed. Cir. 1992), 1571.
- 66. MPEP, *supra* note 4, § 2107.01.

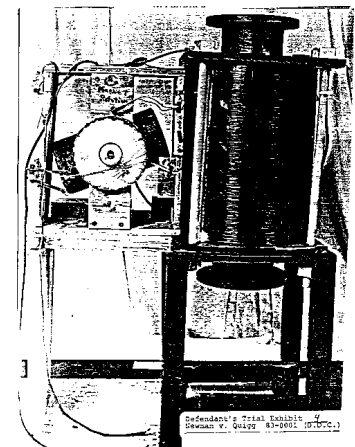

Joseph Newman’s prototype of an “Energy Generation System Having Higher Energy Output Than Input”

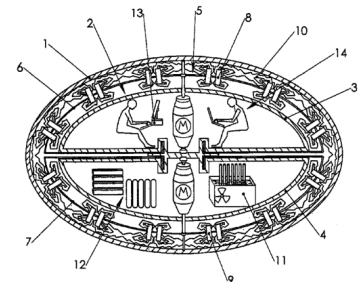

U.S. Pat. No. 6,960,975: Space Vehicle Propelled by the Pressure of Inflationary Vacuum State

matter if the USPTO occasionally issues a patent on a device that violates the known laws of physics?

B Procedures

A patent has two jobs. It must describe the scope of the owner's rights in the invention. This is the job of the claims. It must also disclose the invention in enough detail that others could (if not for the patent) make use of it. This is the job of the *specification*. The process of patent prosecution is designed not just to check that the invention is substantively eligible to be patented, but also to ensure that the claims and specification adequately carry out their jobs.

- [54] **METHOD AND APPARATUS FOR TEMPORARILY IMMOBILIZING AN EARTHWORM**
- [76] **Inventor:** Loren Lukehart, 4391 Greer, Boise, Id. 83703
- [21] **Appl. No.:** 161,144
- [22] **Filed:** Feb. 26, 1988
- [51] **Int. Cl.⁴** A01K 97/02
- [52] **U.S. Cl.** 43/4; 43/4.5; 43/55
- [58] **Field of Search** 43/4, 4.5, 54.1, 55, 43/56, 57.1

[56] **References Cited**
U.S. PATENT DOCUMENTS

1,929,833	10/1933	Vanvuren	43/54.1
2,257,879	10/1941	Graham	43/55
2,507,319	5/1950	Peters	43/55
2,527,214	10/1950	Graves	43/55
3,193,966	7/1965	Lawson et al.	43/55
3,423,869	1/1969	Duerst	43/55

3,566,836 3/1971 Elfert 43/55

Primary Examiner—M. Jordan
Attorney, Agent, or Firm—Frank J. Dykas

[57] **ABSTRACT**

Method and apparatus for immobilization of an earthworm 13 to facilitate the baiting of a fishing hook. To immobilize the earthworm, the earthworm is partially coated with sharp grained sand 11 having a grain size of less than 1/20th of an inch. The apparatus 10 for carrying out the method consists of rectangular container 12 and a reservoir of sharp grained sand 11 and cover 14. Placing earthworm 13 in the apparatus 10 and allowing earthworm 13 to at least partially coat itself with sharp grained sand 11, results in the temporary immobilization of earthworm 13. Earthworm 13 is then impaled on the fishing hook by the fisherman. As soon as the baited hook is immersed in water, the sand is rinsed from earthworm 13 and it resumes wiggling.

3 Claims, 1 Drawing Sheet

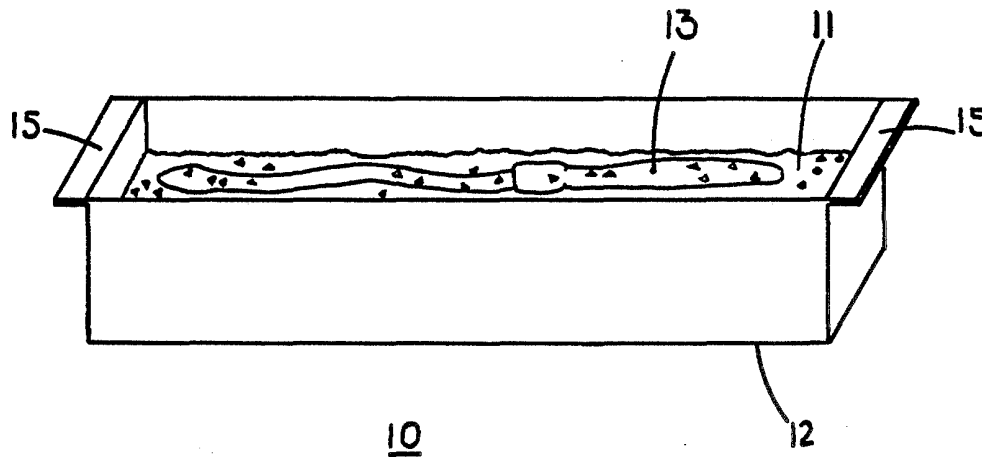

FIG. 1

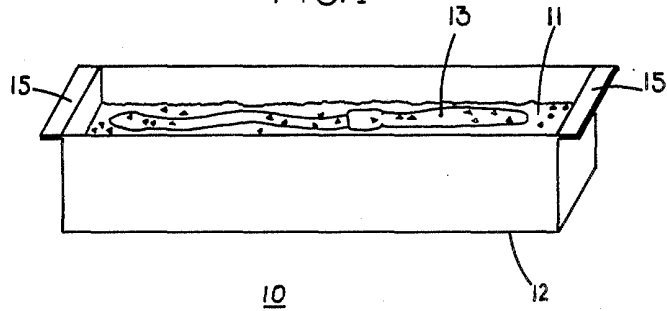

FIG. 2

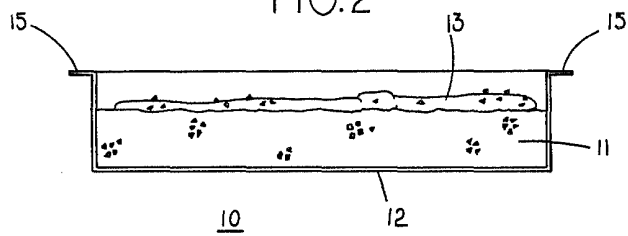
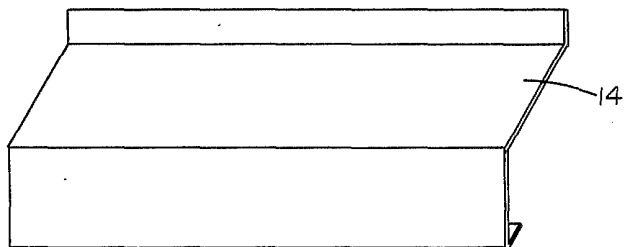

FIG. 3



METHOD AND APPARATUS FOR TEMPORARILY IMMOBILIZING AN EARTHWORM

BACKGROUND OF THE INVENTION

1. Technical Field.

This invention relates to the immobilization of live bait for use in fishing. In particular, the invention relates to a method and apparatus for the dewiggling of earthworms.

2. Background Art.

The use of live bait in fishing has long been known to be one of the most effective means for catching fish. The problem with live bait is that any creature has a natural tendency to resist the baiting process. A further complication in the specific case of earthworms is that they are naturally slimy. The ability of the earthworm to curl its body in almost any direction, connected with the fact that it is coated with slimy film, makes it extremely difficult for the fisherman to impale the earthworm with the fishing hook.

GRAHAM, U.S. Pat. No. 2,257,879, discloses a bait box having a compartment that is filled with a dry sand. The worm is dropped into the dry sand which adheres to the worm's body which makes it easier for the fisherman to hold onto the worm. The problem with the method is that the worm is still able to wiggle and curl its body, making it difficult for the fisherman to impale the worm on the fishing hook.

Accordingly, it is the object of this invention to provide a means for immobilizing an earthworm and thereby facilitating the impalement of the earthworm on a fishing hook by the fisherman.

DISCLOSURE OF INVENTION

These objects are accomplished by coating the earthworm with small sharp grained sand. Small sharp grained sand, as opposed to regular dry sand, has a dramatic affect on the worm's ability to curl its body.

A small rectangular container of sufficient length to harbor an earthworm is partially filled with sharp grained sand having a grain size equal or less than 1/20th of an inch. The rectangular container is also fitted with a removable cover which prevents sand spillage during transport. To dewiggle a worm, the fisherman has to simply set the worm in the rectangular container on top of the sharp grained sand. During the worm's natural locomotion process, the sand becomes partially imbedded in the earthworm and causes an immediate reaction wherein the earthworm completely relaxes. The earthworm is then effectively dewiggled and ready to be impaled onto the fishing hook.

Once the sand coated earthworm is immersed in water, the sand rinses free and the earthworm resume its normal wiggly character.

BRIEF DESCRIPTION OF THE DRAWINGS

FIG. 1 is a top perspective view of the container and sand reservoir with a worm.

FIG. 2 is a sectional side view of the container and sand reservoir with a worm.

FIG. 3 is a perspective view of the container cover.

BEST MODE FOR CARRYING OUT INVENTION

Referring to FIGS. 1, 2 and 3, an apparatus for the immobilization of earthworms is generally designated as

10 and is illustrated in its preferred embodiment. The first and only step in the immobilization of an earthworm by the preferred method is to coat the earthworm with small sharp grained sand 11 having a grain size equal to or less than 1/20th of an inch by momentarily depositing earthworm 13 on sand 11.

The preferred apparatus for the immobilization of an earthworm has a reservoir of sharp grained sand 11 having a grain size equal to or less than 1/20th of an inch, and a rectangular container 12 for housing the sand reservoir.

Sand reservoir container 12 is sized for transverse insertion into a standard bait box, not shown. Retainer lips 15 are attached to and extend perpendicularly out from the top edges of the ends of container 12. Retainer lips 15 are sized for cooperative engagement with the top edges of the sides of the bait box, so that when container 12 is transversely inserted into a bait box it is held suspended above the bottom of the bait box which contains a mixture of live worms and humus material.

Cover 14 is contoured to provide for a seal for sand reservoir container 12 and is held in place by the lid of the standard bait box.

To immobilize earthworm 13, one merely deposits earthworm 13 on top of sand 11. During the earthworm's natural locomotion process individual grains of sand 11 become partially imbedded in earthworm 13 and causes an immediate immobilizing reaction in earthworm 13. As a result earthworm 13 will rapidly straighten out and become immobilized. Since earthworm 13 is covered with grains of sand 11, it is not only immobilized, but also easy to pick up and handle.

Once earthworm 13 has been impaled upon the fisherman's hook, not shown, and immersed in water, said 11 washes off earthworm 13 and earthworm 13 will resume wiggling.

While there is shown and described the present preferred embodiment of the invention, it is to be distinctly understood that this invention is not limited thereto but may be variously embodied to practice within the scope of the following claims.

Accordingly, what I claim is:

1. An apparatus for temporarily immobilizing an earthworm which comprises:
 - a container for housing the a reservoir of sand;
 - a reservoir of sharp sand having a grain size of 1/20th of an inch or less.
2. The apparatus of claim 1 wherein said container further comprises:
 - a rectangular shaped container for holding a reservoir of sand, said rectangular container having a length slightly less than the width of a standard bait box;
 - retainer lips attached to and extending perpendicularly from the ends of said rectangular container for cooperative engagement with the top edges of the sides of a standard bait box for transversely suspending and supporting the rectangular container within the bait box;
 - a cover for cooperative engagement with the rectangular shaped container for containing the sand.
3. A method for immobilizing an earthworm which comprises partially coating said earthworm with a sharp grained sand having a grain size equal to or less than 1/20th of an inch.

* * * * *

A patent lawyer sees the world in terms of *embodiments*: particular things that put an invention into practice. If I have a patent claiming “an insulated pizza box having side vents and racing stripes,” then each pizza box with vents and stripes is a distinct embodiment. This box, which has three vents and red stripes, is an embodiment. That box, which has two vents and yellow stripes, is also an embodiment.

The specification only needs to describe a single embodiment; it has to explain how that embodiment works and what is new about it. The specification is written in ordinary English prose. It may use technical terms that require years of education and experience to understand precisely, but the language itself is natural language.

Claims, on the other hand, describe *sets* of embodiments, and their purpose is to clearly distinguish those things that are covered by the patent from those things that are not. While the specification may describe what is new about the invention and why it is better than the prior art, the claims typically do not.⁶⁷

1 Claims

The U.S. is strictly an examination country and the main purpose of the examination, to which every application is subjected, is to try to make sure that what each claim defines is patentable. To coin a phrase, *the name of the game is the claim*.⁶⁸

Section 112(b) of the Patent Act requires patents to contain claims:

The specification shall conclude with one or more claims particularly pointing out and distinctly claiming the subject matter which the inventor or a joint inventor regards as the invention.⁶⁹

a Claim Drafting

Claims typically follow a rigid format. For example:

What is claimed is:

1. An apparatus for frobulating a thermozorp, comprising a frimble, a circular smorf plate, and a plurality of groozers attached to the frimble and to the smorf plate.
2. The apparatus of claim 1, wherein the smorf plate is positioned beneath the frimble.

It is usually said that each patent claim must be a single sentence, but as this example shows, it would be more precise to say that each claim is a single noun phrase, because the formulaic phrase “What is claimed is” (or close equivalent) is repeated only once at the start of the claims section of the patent.

Claim drafting is a specialized skill, and claim language is full of specialized vocabulary, used precisely. Here, “plurality” is a good example: it means “more than one.” Other terms, like “thermozorp” and

67. See Mark A. Lemley, *Point of Novelty*, 105 Nw. U. L. REV. 1253, 1254 (2011).

68. Giles Sutherland Rich, *Extent of Protection and Interpretation of Claims — American Perspectives*, 21 INT’L REV. INDUS. PROP. & COPYRIGHT L. 497, 499 (1990).

69. 35 U.S.C. § 112(b).

“frimble,” are drawn from the specific technical field of the invention; patent attorneys must either know or be willing to learn how to use these technical terms of art precisely and accurately.

Each claim contains three parts:

- A *preamble* like “An apparatus for frobulating a thermozorp,” which generally describes the claimed invention.
- A *transition* like “comprising.”
- The *body*, which sets out the details of the claim.

A claim is typically considered to be made of individual *elements* (or “limitations”). Here, claim 1 would probably be considered to have three elements: a frimble, a smorf plate, and groozers. There is no hard-and-fast rule on how claims are divided into elements, but punctuation is a good starting point.

Elements matter because the fundamental dogma of patent claims is that a claim covers (or “reads on”) an embodiment if *every element* of the claim is present. A claim to “A, B, and C” is infringed by an embodiment with A, B, and C, but not by one with only A and B. A device consisting of a frimble, a circular smorf plate, and six groozers can infringe Claim 1 above; the claim has three elements, each of which is present in the device. But a device consisting of a frimble and six groozers but no smorf plate cannot infringe: it is missing an element from the claim.

A claim can be narrowed by adding elements, because a claim only covers embodiments that have *all* of claim’s elements. A claim to “A, B, C” is broader and covers more embodiments than a claim to “A, B, C, and D” Devices that have A, B, and C but not D will infringe the first claim, but not the second.

A claim can be broadened by using broader terms (“vehicle” rather than “automobile”) or by listing ranges (“between five and ten” rather than “eight”); the claim covers *any* embodiments that fall within the term or range. Another broadening technique is to use an explicit list of alternatives:

Alternative expressions are permitted if they present no uncertainty or ambiguity with respect to the question of scope or clarity of the claims. A “Markush” claim recites a list of alternatively useable species. A Markush claim is commonly formatted as: “selected from the group consisting of A, B, and C” . . . Inventions in metallurgy, refractories, ceramics, pharmacy, pharmacology and biology are most frequently claimed under the Markush formula but purely mechanical features or process steps may also be claimed by using the Markush style of claiming.⁷⁰

Markush groups require great care and should be attempted only by trained professionals on a closed course.⁷¹

What if a device might has all of the claimed elements, but also more? For example, an embodiment might have a frimble, a smorf plate, groozers, *and* a rotary turboencabulator. Whether this device infringes

70. MPEP, *supra* note 4, § 2173(05/)(h).

71. For example, the members of the group must belong to a recognized class that is known to have common properties.*Id.* § 2117(I)(I)(/)(A).

depends on whether the transition phrase is “open” (yes) or “closed” (no). As the MPEP explains:

The transitional term “comprising”, which is synonymous with “including,” “containing,” or “characterized by,” is inclusive or open-ended and does not exclude additional, unrecited elements or method steps. In *Gillette Co. v. Energizer Holdings Inc.*,⁷² the court held that a claim to “a safety razor blade unit comprising a guard, a cap, and a group of first, second, and third blades” encompasses razors with more than three blades because the transitional phrase “comprising” in the preamble and the phrase “group of” are presumptively open-ended. The transitional phrase “consisting of” excludes any element, step, or ingredient not specified in the claim. The transitional phrase “consisting essentially of” limits the scope of a claim to the specified materials or steps and those that do not materially affect the basic and novel characteristic(s) of the claimed invention.⁷³

72. *Gillette Co. v. Energizer Holdings Inc.*, 405 F.3d 1367 (Fed. Cir. 2005).

73. MPEP, *supra* note 4, § 2111.03.

Thus, a device with A, B, C, and D infringes on a claim to a device “comprising” A, B, and C, but not on a claim to a device “consisting of” A, B, and C.

Another recurring question is whether the preamble limits a claim. Consider a device with a frimble, smorf plate, and groozers that is used to extrude fleebles. If the preamble is limiting, then this device does not infringe the sample claim because the claim covers only devices that frobulate thermozorps. But if the preamble is non-limiting, this device infringes, because it has all three claimed elements.

In general, a preamble limits the invention if it recites essential structure or steps, or if it is necessary to give life, meaning, and vitality to the claim. Conversely, a preamble is not limiting where a patentee defines a structurally complete invention in the claim body and uses the preamble only to state a purpose or intended use for the invention.

Perhaps a hypothetical best illustrates these principles: Inventor A invents a shoe polish for shining shoes (which, for the sake of example, is novel, useful, and nonobvious). Inventor A receives a patent having composition claims for shoe polish. Indeed, the preamble of these hypothetical claims recites “a composition for polishing shoes.” Clearly, Inventor B could not later secure a patent with composition claims on the same composition because it would not be novel. Upon discovering, however, that the polish composition grows hair when rubbed on bare human skin, Inventor B can likely obtain method claims directed to the new use of the composition to grow hair.⁷⁴

74. *Catalina Mktg. Intern. v. Coolsavings.com*, 289 F.3d 801, 808 (Fed. Cir. 2002).

Claims can be either *independent* or *dependent*. A dependent claim refers to and incorporates by reference all of the elements of a previous

claim, to which it then adds additional elements. Claim 1 above is an independent claim; claim 2 is dependent on it. A dependent claim is always narrower than the claim it depends on, because the additional elements mean it covers fewer embodiments. A device with a frimble, a smorf plate, and groozers where the smorf plate is positioned above the frimble infringes on claim 1, but not on claim 2.

b Indefiniteness

The *definiteness* requirement is the most important constraint on how patent claims are drafted. The test for indefiniteness comes from the Supreme Court’s opinion in *Nautlius, Inc. v. Biosig Instruments Inc.*:

[Section 112(b)] requires that a patent specification “conclude with one or more claims *particularly pointing out and distinctly claiming* the subject matter which the applicant regards as [the] invention.” . . . We hold that a patent is invalid for indefiniteness if its claims, read in light of the specification delineating the patent, and the prosecution history, fail to inform, with reasonable certainty, those skilled in the art about the scope of the invention.⁷⁵

In *Nautlius*, the patent claimed a heart-rate monitor built into a hollow bar (e.g. in the handle of an exercise machine) with electrodes “mounted ... in spaced relationship with each other.” On remand, the Federal Circuit held that this language was sufficiently definite. While the claim did not say how far apart the electrodes “in spaced relationship” were from each other (e.g. “one inch” or “six miles”), functional constraints on how they worked, as described in the specification, filled in the gap:

For example, on the one hand, the distance between the live electrode and the common electrode cannot be greater than the width of a user’s hands because claim 1 requires the live and common electrodes to independently detect electrical signals at two distinct points of a hand. On the other hand, it is not feasible that the distance between the live and common electrodes be infinitesimally small, effectively merging the live and common electrodes into a single electrode with one detection point.⁷⁶

Most indefiniteness cases are to similar effect. It is fine if the claim covers a range of embodiments; inventors are allowed to draft broad claims. It is fine if the claim is susceptible to multiple interpretations; that is what claim construction is for. A definiteness problem arises only in the comparatively rare case when “the claims . . . fail to inform, with reasonable certainty, those skilled in the art about the scope of the invention.”

A good example of a claim over the line is *Datamize, LLC v. Plumtree Software, Inc.* The patent there disclosed a software program that allowed a person to author user interfaces for electronic kiosks. Its specification explained, “The authoring system enables the user interface for each individual kiosk to be customized quickly and easily within wide

75. *Nautlius, Inc. v. Biosig Instruments Inc.*, 134 S. Ct. 2120, 905 (2014).

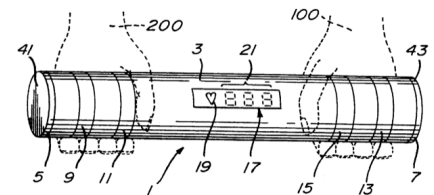

U.S. Pat. No. 5,337,753: Heart Rate Monitor

76. *Biosig Instruments Inc. v. Nautlius, Inc.*, 783 F.3d 1374, 1383 (Fed Cir. 2015).

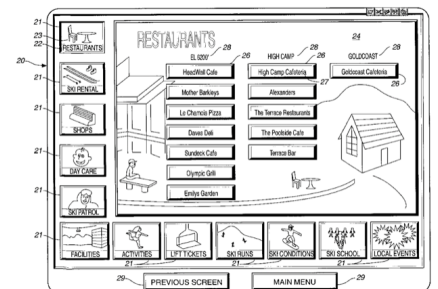

U.S. Pat. No. 6,014,137: Electronic Kiosk Authoring System

limits of variation, yet subject to constraints adhering the resulting interface to good standards of aesthetics and user friendliness.” So far, so good; the specification is allowed to speak in generalities. But the relevant claim included a limitation that the customization allow “limited variation in its on-screen characteristics in conformity with a desired uniform and *aesthetically pleasing* look and feel.” This, the court held, was indefinite:

Here Datamize has offered no objective definition identifying a standard for determining when an interface screen is “aesthetically pleasing.” In the absence of a workable objective standard, “aesthetically pleasing” does not just include a subjective element, it is completely dependent on a person’s subjective opinion. . . .

Major aesthetic choices apparently may include some aspect of button styles and sizes, window borders, color combinations, and type fonts. The written description, however, provides no guidance to a person making aesthetic choices such that their choices will result in an “aesthetically pleasing” look and feel of an interface screen. For example, the specification does not explain what factors a person should consider when selecting a feature to include in the authoring system. Left unanswered are questions like: which color combinations would be “aesthetically pleasing” and which would not? And more generally, how does one determine whether a color combination is “aesthetically pleasing”?⁷⁷

A few claim-drafting techniques are used to avoid indefiniteness. One is the habit of using “a” the first time a noun is introduced in a claim but “the” thereafter (e.g., “a frimble . . . groozers attached to *the* frimble”). This is to avoid the problem of a so-called “lack of antecedent basis:

The lack of clarity could arise where a claim refers to “said lever” or “the lever,” where the claim contains no earlier recitation or limitation of a lever and where it would be unclear as to what element the limitation was making reference. Similarly, if two different levers are recited earlier in the claim, the recitation of “said lever” in the same or subsequent claim would be unclear where it is uncertain which of the two levers was intended.⁷⁸

77. *Datamize, LLC v. Plumtree Software, Inc.*, 417 F.3d 1342, 1350–52 (Fed. Cir. 2005).

78. *MPEP*, *supra* note 4, § 2173.05(e).

Freeny v. Apple Inc.

No.2:13–CV–00361–WCB, 2014 WL 4294505 (E.D. Tex. Aug. 28, 2014)

[Patent No. 7,110,744 described a single device that can communicate wirelessly with a variety of providers, such as hotel systems, vehicle parking systems, and toll systems, using multiple frequencies. It claimed:

A communication unit connected to a public communication

system⁷⁹, the communication unit capable of detecting a plurality of wireless devices and servicing each of the plurality of wireless devices by providing access to the public communication system when the wireless devices are within a predetermined proximity distance from the communication unit, the communication unit comprising [various elements, including a] transceiver simultaneously communicating with at least two wireless devices with different types of low power communication signals.]

79. For "public communication system," think "Internet"

The final term in dispute for purposes of claim construction is the term "low power communication signals." The plaintiffs argue that the term "low power communication signals" should be construed to mean "signals having a power for transmission up to a maximum of several hundred feet." The defendant argues that the term is indefinite because the words "low power" are wholly lacking in specificity. . . .

Indefiniteness is a legal determination; if the court concludes that a person of ordinary skill in the art, with the aid of the specification, would understand what is claimed, the claim is not indefinite. For example, the term "substantially" has frequently been held not indefinite if a person of ordinary skill can discern from the claims and specification what the bounds of the claim are with reasonable certainty. [Cases cited found the terms "about 0.06," "substantially planar," "to increase substantially," "not interfering substantially," "relatively small," "substantially equal to," "closely approximate," and "about 5:1 to about 7:1" not indefinite.] On numerous occasions, district courts, including this court, have held similarly imprecise claim language not indefinite. [Cases cited found the phrases "substantially collimated," "roughly the same," "low frequency forces," "low hydroxyl ion content," and "low DC electrical voltage" not indefinite.] . . .

In light of the applicable caselaw, including the *Nautlius* case, the Court concludes that the term "low power communication signals" is not indefinite. The specification on several occasions refers to low power signals as those that do not communicate farther than a few hundred feet. *See, e.g.*, '744 patent, col. 32, ll. 29–31 ("low power wireless link ... does not typically communicate farther than about 300 feet"); col. 35, ll. 50–51 (detection range of "say several hundred feet"); col. 36, ll. 31–38 (wireless connection ranges "will vary from several hundred feet to only several feet"); col. 39, ll. 13–15 (transmissions possible "within several hundred feet" of a communication unit); col. 7, ll. 4–8 (transceiver capable of communicating "up to at least a predetermined proximity distance such as a hundred feet"); col. 13, ll. 49–52 (different signal strengths designed for detection at 500 feet and 20 feet); col. 16, ll. 49–51 (authorization distance set at 500 feet and 20 feet). Moreover, the plaintiffs' expert filed a declaration pointing to the references in the patent to infrared signals, 900 MHz signals, 1.8 GHz signals, and 2.4 GHz signals as examples of different types of low power communication signals. He explained that a common characteristic of such signals is the limited distance over which they can be transmitted, as discussed in the specification. One of ordinary skill in the art, he explained, would understand from reading

the '744 specification that the claim term “different types of low power communication signals” means “different types of communication signals having a power for transmission up to a maximum of several hundred feet.” The defendant has not submitted a contrary expert declaration on the issue of indefiniteness.

Accordingly, the Court concludes that the term “low power communication signals,” viewed in light of the specification, would be understood by persons of skill in the art with reasonable certainty. The asserted claims in the '744 patent are therefore not indefinite. Furthermore, in light of the discussion of low power communications in the specification, the Court agrees with the plaintiffs that the term should be interpreted to mean “communication signals having a power for transmission of up to a maximum of several hundred feet.”

Worm Patent Questions

Consider U.S. Patent No. [4,800,666](#), reproduced above in section B.

1. Who is Loren Lukehart? What was their role with respect to this patent?
2. Who is M. Jordan? What was their role with respect to this patent?
3. Who is Frank J. Dykas? What was their role with respect to this patent?
4. When was this patent application filed?
5. When did this patent issue?
6. Is this patent still enforceable?
7. What does this invention do, and how does it work?
8. What part of this patent is the specification? What part is the claims?
9. How many claims does this patent have? Are they product or method claims? How many are independent, and how many are dependent? What are their elements?
10. Are any of the claims indefinite?
11. If you wanted to find out more about this technology and other patents in the same field, where would you look?
12. Why did the inventor seek a patent for this technology? Was it worth it?

2 Disclosure

Section 112(a) of the Patent Act describes what a patent’s specification must disclose:

The specification shall contain a written description of the invention, and of the manner and process of making and using it, in such full, clear, concise, and exact terms as to enable any

person skilled in the art to which it pertains, or with which it is most nearly connected, to make and use the same, and shall set forth the best mode contemplated by the inventor or joint inventor of carrying out the invention.⁸⁰

The Federal Circuit has held that this language creates three distinct requirements: *enablement*, *written description*, and *best mode*.

a Enablement

The enablement requirement is what fundamentally distinguishes patent from trade secret. The key phrase is “in such full, clear, concise, and exact terms as to enable any person skilled in the art to which it pertains . . . to make and use the same.”⁸¹ When the patent expires, everyone in the world will have the legal right to use the invention. The enablement requirement ensures that when they do, they will also have the practical ability to use it. In the meantime, even if they are legally prohibited from using the invention, they can still study the patent to understand how the invention works, building on the knowledge patent discloses.

This is the heart of the patent bargain: exclusive rights to the invention in exchange for explaining publicly how it works. The enablement requirement prevents inventors from writing overbroad claims that go too far beyond what they have actually contributed to society with their invention and disclosure.

Enablement is closely related to utility. An invention that lacks utility because it is not operable is typically also not enabled. An inventor who cannot even make the invention work themselves is unlikely to be able to describe it clearly enough for a PHOSITA to make it work.

The most common enablement issues arise when the inventor has successfully developed one embodiment (a *species*) but writes a broader claim that covers numerous related embodiments (a *genus*). The rule is that the specification must enable the *full scope of the claims*:

If a patent claims an entire class of processes, machines, manufactures, or compositions of matter, the patent’s specification must enable a person skilled in the art to make and use the entire class. In other words, the specification must enable the full scope of the invention as defined by its claims. The more one claims, the more one must enable.⁸²

One way for a genus claim to fail to be enabled is when only some members of the claimed genus lack the properties that make the invention new and useful. A classic is *the Incandescent Lamp Patent*, a dispute about inventorship of the light bulb. An *incandescent* lamp is – quite literally – a lamp in which a thin filament is heated with electric current until it glows. One of the crucial engineering problems was determining the best material for a filament. One pair of inventors, William Sawyer and Albon Man, developed a lamp with a “carbonized paper” filament. They filed for and were granted a patent claiming an “incandescing con-

80. 35 U.S.C. § 112(a).

81. This section omits the word “having,” so to be precise, we should call the PHOSITA a POSITA here.

82. *Amgen Inc. v. Sanofi*, 143 S. Ct. 1243, 1254 (2023).

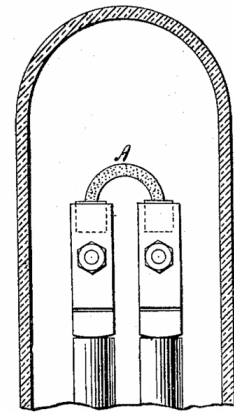

U.S. Pat No. 317,676: Electric Light

ductor for an electric lamp, of carbonized fibrous or textile material.” When Thomas Edison’s laboratory created a commercially successful lamp with a filament made from bamboo stem, they sued, as bamboo is a material made of fibers.⁸³

The Supreme Court held that Sawyer and Man had not made an enabling disclosure, because the properties that made this part of this species of bamboo particularly suitable as a filament were not properties widely shared by fibrous materials generally:

If the patentees had discovered in fibrous and textile substances a quality common to them all, or to them generally, as distinguishing them from other materials, such as minerals, etc., and such quality or characteristic adapted them peculiarly to incandescent conductors, such claim might not be too broad. . . . Sawyer and Man supposed they had discovered in carbonized paper the best material for an incandescent conductor. Instead of confining themselves to carbonized paper, as they might properly have done, and in fact did in their third claim, they made a broad claim for every fibrous or textile material, when in fact an examination of over six thousand vegetable growths showed that none of them possessed the peculiar qualities that fitted them for that purpose. . . .

[H]ow would it be possible for a person to know what fibrous or textile material was adapted to the purpose of an incandescent conductor, except by the most careful and painstaking experimentation?⁸⁴

The point is that Sawyer and Man had not provided sufficient details about their claimed “fibrous or textile material” to enable others to determine *which* fibrous or textile material would actually work. Finding the one fibrous material that actually works well within the vast class of all fibrous materials requires more experimentation than it is reasonable to ask a POSITA to carry out.⁸⁵

Amgen Inc. v. Sanofi is a good modern example. A naturally-occurring protein called PCSK9 reduces the body’s ability to remove harmful cholesterol from the blood. Amgen researched antibodies – other proteins – that could bind to PCSK9 in a way that inhibited its effects. It filed a patent application claiming antibodies that “bind to specific amino acid residues on PCSK9,” and block PCSK9’s effects. Each antibody is defined by the sequence of amino acids that make it up, so Amgen filed a patent application describing the amino-acid sequences of 26 distinct antibodies that bind to PCSK9.

The Supreme Court held that this was not an enabling disclosure, because to find an antibody that works, a POSITA would need to make numerous antibodies and then test them in the lab to see whether they bind to PCSK9 and block its effects.

Think about it this way. Imagine a combination lock with

83. *The Incandescent Lamp Pat.*, 159 U.S. 465, 471 (1895).

84. *Id.*

85. Edison’s well-funded lab went far above and beyond the level of effort expected of a POSITA. Among other things, he tested over six thousand different types of plant substances, and dispatched an agent to Japan and China to source forty different types of bamboo for testing.

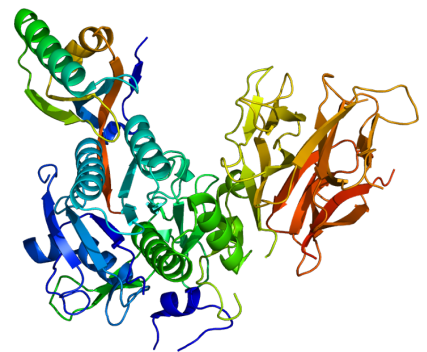

The molecular structure of PCSK9.

100 tumblers, each of which can be set to 20 different positions. Through trial and error, imagine that an inventor finds and discloses 26 different successful lock combinations. But imagine, too, that the inventor tries to claim much more, namely all successful combinations, while instructing others to randomly try a large set of combinations and then record the successful ones. Sure enough, that kind of roadmap would produce functional combinations. But it would not enable others to make and use functional combinations; it would instead leave them to random trial-and-error discovery.⁸⁶

The issue, here as in *Incandescent Lamp*, is the *unpredictability* of the required experiments. As another court put it, “Even a considerable amount of experimentation is permissible, as long as it is merely routine or the specification provides a reasonable amount of guidance regarding the direction of experimentation.”⁸⁷ The biological sciences are particularly unpredictable; in other fields, it is often easier to predict what an embodiment will do without the expense and difficulty of synthesizing and testing it in a lab.

Plastic Dye Problem

You are drafting claims for a patent application for an industrial dye that turns certain plastics an attractive shade of blue. Your client has tested it, with success, on PETE, HDPE, PEEK, and PVDC (all semi-crystalline plastics). How should you draft a claim to the dye?

b Written Description

The written description requirement has no clear textual basis. The Federal Circuit’s best attempt to explain the doctrine is from its *en banc* in *Ariad Pharmaceuticals, Inc. v. Eli Lilly & Co*:

Specifically, the description must clearly allow persons of ordinary skill in the art to recognize that the inventor invented what is claimed. In other words, the test for sufficiency is whether the disclosure of the application relied upon reasonably conveys to those skilled in the art that the inventor had possession of the claimed subject matter as of the filing date.⁸⁸

Perhaps a concrete example will help. In *Gentry Gallery, Inc. v. Berklene Corp.*, James Sproule described a sectional sofa with two independent recliners facing in the same direction, so that both people can watch TV without turning their heads.⁸⁹ This raised the design question of where to put the recliner controls, which would normally go on the exposed end of a sofa section. The patent claimed “a fixed console” located between the two recliners and “and a pair of control means, one for each reclining seat; mounted on the double reclining seat sofa section.”

86. *Amgen*, 143 S. Ct. at 1257 (internal quotation omitted).

87. *Wyeth & Cordis Corp. v. Abbott Labs.*, 720 F.3d 1380, 1386 (Fed. Cir. 2013).

88. *Ariad Pharms., Inc. v. Eli Lilly & Co*, 598 F.3d 1336, 1351 (Fed Cir. 2010).

89. *Gentry Gallery, Inc. v. Berklene Corp.*, 134 F.3d 1473 (Fed. Cir. 1998).

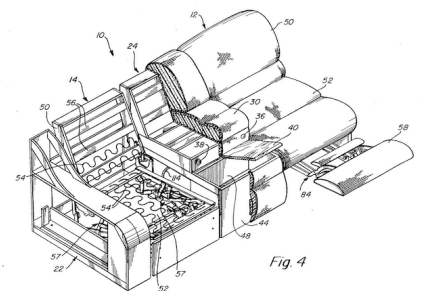

U.S. Pat. No. 5,064,244: Reclining Sofa

These claims failed, the Federal Circuit held, because “the patent’s disclosure does not support claims in which the location of the recliner controls is other than on the console.”⁹⁰ More specifically,

In this case, the original disclosure clearly identifies the console as the only possible location for the controls. It provides for only the most minor variation in the location of the controls, noting that the control “may be mounted on top or side surfaces of the console rather than on the front wall ... without departing from this invention.” No similar variation beyond the console is even suggested. Additionally, the only discernible purpose for the console is to house the controls. As the disclosure states, identifying the only purpose relevant to the console, “[a]nother object of the present invention is to provide ... a console positioned between [the reclining seats] that accommodates the controls for both of the reclining seats.” Thus, locating the controls anywhere but on the console is outside the stated purpose of the invention. . . . Accordingly, when viewed in its entirety, the disclosure is limited to sofas in which the recliner control is located on the console.⁹¹

This is not an enablement problem, because there was no particular technical difficulty in putting the controls where they normally would have gone, on the exposed ends of the sofa. So written description is doing some work that enablement does not.

Gentry Gallery also hints at why the Federal Circuit feels that written description is necessary. The inventor, James Sproule, does not seem to have had any thought that a double recliner with a console might put the controls somewhere else. From his point of view, the reason to have a console was to put the controls there. But then the defendant, Berkline, released a double-recliner sectional sofa with a cushion that could fold down to make a tabletop between the recliners, and *Gentry* wanted to argue that its claims covered Berkline’s design. If the tabletop was a “console,” then Berkline’s sofa did indeed have a both a “fixed console” between the recliners and “a pair of control means” for the recliners. So written description polices attempts by inventors to stretch their claims to reach beyond what they actually invented.

c Best Mode

I will let the MPEP explain best mode:

The best mode requirement is a safeguard against the desire on the part of some people to obtain patent protection without making a full disclosure as required by the statute. The requirement does not permit inventors to disclose only what they know to be their second-best embodiment, while retaining the best for themselves. . . .⁹²

Failure to disclose the best mode need not rise to the

90. *Id.* at 1479.

91. *Id.*



A double-recliner sofa (*not* a Berkline) with a fold-down tabletop between the seats



Marshawn “Best Mode” Lynch

92. How can a patent examiner tell whether an application discloses the best mode or the second-best mode?

level of active concealment or inequitable conduct in order to support a rejection. Where an inventor knows of a specific material or method that will make possible the successful reproduction of the claimed invention, but does not disclose it, the best mode requirement has not been satisfied.⁹³

93. MPEP § 2165

The theory behind best mode is that it prevents inventors from engaging in a whipsaw by obtaining a patent while keeping key technical details as a trade secret. Others can technically make and use the invention (as enablement requires), but the inventor retains as trade secrets enough operational details that anyone else's version will be a poor imitation of theirs.

In practice, however, determining what counted as the "best" mode turned out to be a litigation tarpit, leading to pressure on Congress to repeal the best mode requirement entirely. Instead, it split the difference.

Section 15 of the Leahy-Smith America Invents Act (AIA) did not eliminate the requirement for a disclosure of the best mode, but . . . it amended 35 U.S.C. 282 (the provision that sets forth defenses in a patent validity or infringement proceeding) to provide that the failure to disclose the best mode shall not be a basis on which any claim of a patent may be canceled or held invalid or otherwise unenforceable.⁹⁴

94. MPEP § 2165

So now, the USPTO can raise best mode objections to a patent application, but defendants cannot raise them in patent litigation.

Salt Shaker Problem

Assume that you represent the inventor of the first screw-top salt shaker. (In this alternate universe, prior art salt shakers were filled through a hole in the bottom.) Draft a claim for this new invention. Suggestions:

- What are the constituent parts of the screw-top shaker? Your claim will need to describe them and explain how they are related.
- Which features of the screw-top shaker are essential to its use? Which can safely be omitted?
- Once the new screw-top shaker is publicly available, competing shaker-makers will try to invent around the patent. How can you make their job harder?
- Inventors in other industries may be inspired by the screw-top design. Can you make sure that your claim is not restricted to the one use your client has in mind?



The screw-top salt shaker

3 Patent Prosecution

Patent has the most extensive and expensive procedures of any IP area. Unlike trade secret protections, which are effective immediately and

with no procedural prerequisites, an inventor obtains patent rights only by completing an extensive application process at the USPTO and paying **substantial fees**. Terminologically, the USPTO engages in patent “examination” and the applicant engages in patent “prosecution.”

Patent Examination

A complete application requires a specification, claims, and a signed oath by each inventor. The USPTO strongly prefers that applicants use its electronic filing system, **EFS-Web**; applications filed on paper require an additional fee. Once the USPTO receives the application, it will be assigned to a patent *examiner* with technical expertise in the patent’s field (molecular biologists will not review aeronautical engineering patents, or vice versa). The examiner will compare the application to the relevant prior art (starting with any references identified in the application itself, but also conducting their own search).

After reviewing the application, the examiner will send the applicant a letter called an *office action*, typically listing reasons the examiner believes particular claims are not patentable in their present form. The applicant can then amend the claims or present evidence to argue its case. The examiner will then issue another office action, and so on. This process continues until the examiner has no more objections to the (possibly revised) claims, the applicant withdraws the application, or the examiner issues a *final* office action (which the applicant can then appeal).

Applications are confidential when filed.⁹⁵ It is only *publication* of a patent or application that destroys trade secrecy, not the process of applying for a patent. A patent is published when it issues, so in this case the transition from trade secrecy to patent protection is automatic. A patent application is also published 18 months after its priority date (see below), subject to an exception for applications made only in the United States or other countries that do not publish patent applications. This looks like it can leave a gap between publication and issuance, which it does – but a patent owner can retroactively recover a “reasonable royalty” from an infringer who had actual notice of a published application.⁹⁶

Practice before the USPTO is and is not the practice of law. Patent examiners need technical training but do not need to have law degrees; indeed, some of them go on to law school after working at the USPTO. To be a patent *agent* who represents clients and files their applications with the USPTO, one must be admitted to the “patent bar,” or more formally, registered to practice before the USPTO. This requires passing an examination on patent practice, substantially based on the MPEP. It also requires having a degree in a technical field; the USPTO’s narrow definitions of which majors and courses are eligible is a notorious source of exclusion within patent law.⁹⁷ Not included: being a lawyer. One can be a patent agent without passing a state bar exam or attending law school. The USPTO enforces its own rules of discipline, and patent prac-

95. patent122

96. 35 U.S.C. § 154(d).

97. See William Hubbard, *Razing the Patent Bar*, 59 ARIZ. L. REV. 383 (2017).

tice involves some distinctive ethical issues that attorneys who also are admitted to practice before the USPTO must be mindful of.

Priority Dates

Every patent application has a *priority date*, which is of critical importance in determining whether it is patentable at all, when its term will run, and which of several competing applications has priority (hence the name). The priority date is normally its *filing date*: the date that a complete application is filed. Thus, the priority date is often called the *effective filing date*.

There are some twists on this rule, but they all follow a common theme: an application is entitled to priority based on when its *specification* was filed. Claims can be amended during prosecution without losing priority, but changes to the specification reset the priority date.

First, an inventor may file a placeholder *provisional* application.⁹⁸ Provisional applications have a specification, but are not required to have claims or inventors' oaths. They are not examined; the point of filing one is simply to reserve one's place in line by locking down a priority date. An applicant who files a provisional application has one year to file a corresponding regular nonprovisional application – i.e., repeating the same specification, adding claims and oath, and asserting priority based on the provisional. If they do, the nonprovisional application is given the earlier priority date of the provisional application it refers back to. If the applicant does not follow up within one year, it is treated as abandoned, and they lose the priority date.

98. 35 U.S.C. § 111(b).

Second, sometimes an inventor may split up an application after filing. For example, if the examiner rejects some but not all of its claims, the inventor is on the horns of a dilemma: appeal the rejected claims and delay the entire application, or let those claims go and have the allowable ones issue now? A *continuation* application resolves the dilemma by letting the inventor file a new patent application with different claims based on the same specification as its "parent" application, and thus with the same priority date. Now the inventor can have one patent that issues immediately, while using another application to carry on the argument as to the disputed claims. Continuations are flexible tools, so it is common for one application to branch off multiple continuations as the inventor's patent counsel refines their strategy over time.

Closely related is the *continuation-in-part* application, which is like a continuation except that its specification can include *new matter* not disclosed in its parent's specification. Because of the new matter, so it is not automatically entitled to the same priority date. Instead, priority dates are assessed on a claim-by-claim basis.

Also closely related is the *divisional* application. Sometimes the USPTO determines that an application claims "two or more independent and distinct inventions."⁹⁹ If so, the inventor may restrict the application's claims to one of the two inventions and also file a *divisional* application for the other. Like a continuation, a divisional application

99. 35 U.S.C. § 121. The rule against claiming multiple distinct inventions is an examination rule that the USPTO can enforce for its convenience, not a grounds on which others can challenge the patent's validity.

repeats (some or all of) the specification from its parent, so it keeps the same priority date.

A continuation, continuation-in-part, or divisional cannot be split off from an application once it issues. Thus, inventors will sometimes branch off a continuation from an about-to-issue application just to keep their options open.

One common defense of the written-description requirement is that it prevents savvy patent agents from excessively amending their claims during prosecution to cover later technological developments. If Berkline's fold-down tabletop becomes the dominant design for sectional sofas, Sproule will want to amend his already-filed patent application to cover this configuration. Because the specification is fixed, written description anchors the claims to the specification as actually filed. But if the problem is abusive amendment practice, then perhaps the rules about priority dates, claim amendments, and new matter should be amended to limit abusive amendments.¹⁰⁰

Inequitable Conduct

Patent applicants have a duty of candor and good faith to the USPTO.¹⁰¹ In particular, they must disclose any information they know "to be material to patentability." Typically and most importantly, this means calling the examiner's attention to any prior art references that might make the invention non-novel or obvious.

Mere failure to disclose relevant prior art is not automatically actionable. But intentionally deceiving the USPTO is, and can lead to a finding of *inequitable conduct*, which renders the patent unenforceable. The Federal Circuit's leading case on inequitable conduct is *Therasense, Inc. v. Becton, Dickinson & Co.*:

To prevail on a claim of inequitable conduct, the accused infringer must prove that the patentee acted with the specific intent to deceive the PTO. A finding that the misrepresentation or omission amounts to gross negligence or negligence under a "should have known" standard does not satisfy this intent requirement. In a case involving nondisclosure of information, clear and convincing evidence must show that the applicant made a deliberate decision to withhold a known material reference. In other words, the accused infringer must prove by clear and convincing evidence that the applicant knew of the reference, knew that it was material, and made a deliberate decision to withhold it.

Because direct evidence of deceptive intent is rare, a district court may infer intent from indirect and circumstantial evidence. However, to meet the clear and convincing evidence standard, the specific intent to deceive must be the single most reasonable inference able to be drawn from the evidence. Indeed, the evidence must be sufficient to *require*

100. It is not clear that original, unamended, applications raise the same concerns, even though *Ariad Pharmaceuticals* insists that the written description doctrine applies to them too.

101. 37cfr156 at /a

a finding of deceitful intent in the light of all the circumstances.

This court holds that, as a general matter, the materiality required to establish inequitable conduct is but-for materiality. When an applicant fails to disclose prior art to the PTO, that prior art is but-for material if the PTO would not have allowed a claim had it been aware of the undisclosed prior art.¹⁰²

Do not lie to the USPTO. Do not try to hide prior art from the USPTO. Inequitable conduct is invalidity in all but name.

Issuance

If and when the examiner agrees that an application's claims are patentable and the applicant pays the appropriate fees, the patent will *issue*. The patent is given a number, and once a week – at the stroke of midnight, Eastern Time, between Monday and Tuesday – the USPTO posts the new patents to its **Official Gazette for Patents**. The patent becomes effective as of issuance, and the patentee receives the legal right to enforce their patent against others.

Formerly, the patentee would also receive the “letters patent” from which patents take their name: a fancy piece of paper with a gold seal signed by the director of the USPTO. But the USPTO discontinued this practice in 2023, and now issues all patents electronically, with a digital seal and signature.¹⁰³

Judicial Review

Applicants can appeal rejections to the Patent Trial and Appeal Board (PTAB).¹⁰⁴ If the PTAB also rejects the application, the applicant can seek judicial review either before the Federal Circuit¹⁰⁵ or the Eastern District of Virginia.¹⁰⁶

Post-Grant Proceedings

There are a bewildering variety of procedures available to review patents once they have issued, and the menu has changed over time.

- In *reissue*, when a patent is “through error, deemed wholly or partly inoperative or invalid, by reason of a defective specification or drawing, or by reason of the patentee claiming more or less than he had a right to claim in the patent,” the patentee can have it reissued with different claims.¹⁰⁷ Reissue with the first two years after issuance can expand the claims; after that, only narrowing amendments are allowed.
- In *ex parte reexamination*, any person can call prior art to the attention of the USPTO.¹⁰⁸ If the USPTO agrees that the prior art raises “a substantial new question of patentability,” it can initiate reexamination and cancel any claims it now finds to be unpatentable. *Ex parte* reexamination can also be initiated by the

102. *Therasense, Inc. v. Becton, Dickinson & Co.*, 649 F.3d 1276, 1290–91 (Fed. Cir. 2011).



Certified copy of U.S. Pat. No. 5,860,492

103. USPTO Officially Transitions to Issuing Electronic Patent Grants in 2023, 88 Federal Register 12560 (Pat. & Trademark Off. 2023).
104. 35 U.S.C. § 134(a).
105. § 141.
106. § 145. The USPTO's headquarters are in Alexandria, Virginia, that's why.
107. § 251.
108. 35 U.S.C. §§ 302 *et seq.* .

USPTO itself. This is, as the name indicates, a procedure akin to initial examination, between the patentee and the USPTO. As with initial examination, the patentee can seek judicial review of a rejection.

- By contrast, **inter partes reexamination** is an adversary procedure between a third party and the patentee before the PTAB.¹⁰⁹ The USPTO has unappealable discretion whether or not to initiate an IPR once a third party requests one, but the PTAB's decision to cancel (or not) a patent at the end of an IPR can be appealed to the Federal Circuit. Because an IPR gives patent defendants another bite at the apple to challenge a patent, they are not allowed to file an IPR request more than a year after being served with an infringement complaint. IPRs raise complicated preclusion and administrative-law issues, so be warned that tactical litigation decisions involving them can be highly consequential.
- **Post-grant review** (PGR) is only available within nine months after a patent issues.¹¹⁰ IPR becomes available after the nine-month PGR window closes. The major differences are that IPR only allows for challenges under Sections 102 (novelty) and 103 (nonobviousness) and that the threshold for the PTO to hear an IPR is higher.

109. 35 U.S.C. §§ 311 *et seq.* .

110. 35 U.S.C. §§ 321 *et seq.* Until 2020, there was a "transitional" program that allowed for PGR of any "covered business method patent" at any time. For guidance on what is and is not a covered business method, see *Unwired Planet, LLC v. Google Inc.*, 841 F.3d 1376 (Fed. Cir. 2016).

4 Term

Once a patent issues, it is valid for a term of 20 years from its priority date.¹¹¹ Thus, continuations and divisionals cannot be used to push out the date on which a patent will expire. The price an inventor pays for seeking a further-out end of the patent term is losing their place in line – and accepting a broader universe of prior art – by giving up the earlier priority date. There are also an extensive and intricate set of provisions for extending the patent term "if the issue of an original patent is delayed due to the failure of the Patent and Trademark Office" to act expeditiously, as specified by the statute, in its examination of the application.¹¹²

111. 35 U.S.C. § 154(a)(2).

112. 35 U.S.C. § 154(b).

C Ownership

Now that we have cleared away the questions of *what* can be patented (almost anything, with a few exceptions) and *how* an inventor can obtain a patent (examination of the claims in an application making sufficient disclosure), we can turn to the densely interlocking rules that govern *who* is entitled to a patent and *when*. The basic concepts here are *inventorship*, *novelty* and *statutory bar*, and *obviousness*. In outline form, inventorship determines who is an inventor entitled to file an application for patent, and the other requirements determine when they have done enough that their invention is actually patentable.

1 Inventorship

The Patent Act helpfully, if circularly, explains that the term “inventor” means “the individual or, if a joint invention, the individuals collectively who invented or discovered the subject matter of the invention.”¹¹³ In *Thaler v. Vidal*, the technologist Steven Thaler submitted an invention purportedly “created” by a system named DABUS.¹¹⁴ The USPTO rejected the application, and the Federal Circuit agreed, explaining that “individual” unambiguously means a human being.

Today, any person can be an inventor, as “Whoever invents or discovers any new and useful [invention] may obtain a patent therefore”¹¹⁵ But in 1858, following the Supreme Court’s notorious and explicitly racist decision in *Dred Scott v. Sandford* that Black people could not be citizens,¹¹⁶ the Attorney General issued a brief opinion that a new type of plow invented by an enslaved Black person named Ned could not be patented.¹¹⁷ According to the opinion, as a non-citizen, Ned could not take the required inventor’s oath. Because *Dred Scott* applied to all Black people, enslaved and free, the effect of the opinion was to completely bar Black inventors from obtaining patents. The Fourteenth Amendment, passed in the wake of the Civil War, reversed this restriction by declaring, “All persons born or naturalized in the United States, and subject to the jurisdiction thereof, are citizens of the United States”¹¹⁸

A person becomes an “invent[or]” within the meaning of Section 101, and thus entitled to obtain for a patent, when they *conceive* of the invention. The MPEP explains:

Conception has been defined as “the complete performance of the mental part of the inventive act” and it is “the formation in the mind of the inventor of a definite and permanent idea of the complete and operative invention as it is thereafter to be applied in practice.” Conception is established when the invention is made sufficiently clear to enable one skilled in the art to reduce it to practice without the exercise of extensive experimentation or the exercise of inventive skill. Conception has also been defined as a disclosure of an invention which enables one skilled in the art to reduce the invention to a practical form without “exercise of the inventive faculty.” It is settled that in establishing conception a party must show possession of every feature recited in the count, and that every limitation of the count must have been known to the inventor at the time of the alleged conception. Conception must be proved by corroborating evidence. In *Hitzeman v. Rutter*,¹¹⁹ the inventor’s “hope” that a genetically altered yeast would produce antigen particles having the particle size and sedimentation rates recited in the claims did not establish conception, since the inventor did not show that he had a “definite and permanent understanding” as to whether or how, or a reasonable expectation that, the yeast

113. 35 U.S.C. § 100(f).

114. *Thaler v. Vidal*, — F.4th — (Aug. 5, 2022).

115. 35 U.S.C. § 101 (emphasis added).

116. *Dred Scott v. Sandford*, 60 U.S. (19 How.) 393 (1857).

117. *Invention of a Slave*, 9 Op. Att’y Gen. 171 (1858).

118. UNITED STATES CONSTITUTION, *supra* note 2, amend. 14 S 1. See generally Kara J. Swanson, *Race and Selective Legal Memory: Reflections on Invention of a Slave*, 120 COLUM. L. REV. 1077 (2020); Brian L. Frye, *Invention of a Slave*, 68 SYRACUSE L. REV. 181 (2018).

119. *Hitzeman v. Rutter*, 243 F.3d 1345 (Fed. Cir. 2001).

would produce the recited antigen particles. There must be a contemporaneous recognition and appreciation of the invention for there to be conception.¹²⁰

120. MPEP, *supra* note 4, § 2138.

To repeat, inventors' rights derive from conception; conception is what makes one an inventor.

The inventor need not have built anything or worked out the technical details at the moment of conception. The phrase "reduce the invention to a practical form" refers to another, and later stage of patent law's vision of the inventive process: *reduction to practice*. That occurs when the invention has been made "in a physical or tangible form" and "sufficiently tested to demonstrate that it will work for its intended purpose."¹²¹ If the inventor who "conceives" of an invention is described as though they were pregnant with it, then reduction to practice is the metaphorical "birth."

121. mpep at 2138.

Reduction to practice was much more important under pre-AIA law, but it is still important enough that you should know what it is. Some inventions are so simple that construction alone is a reduction to practice; in other cases (think of a candidate protein from *Amgen*), testing is required to know that the invention will work.¹²²

122. Amusingly, the inventor need not know *why* the invention works, only that it does.

A patent application by itself is proof of conception, and is regarded as constructive reduction to practice of anything it describes, whether or not the invention works. Some patents even use "prophetic" examples, in which an inventor describes an embodiment they think will work but have not actually made. This practice can be particularly confusing for scientists who read patents and assume that people only publish the results of experiments they have carried out.¹²³

123. See Janet Freilich, *Prophetic Patents*, 53 U.C. DAVIS L. REV. 663 (2019).

Collaborations

Each person who contributes to the conception of at least one claim in a patent is a joint inventor. Everyone who does not is not. Suggesting an idea for a result isn't enough; neither is taking someone else's idea and reducing it to practice. The MPEP says that an inventor who maintains "intellectual domination" of the work is still an inventor even if others made suggestions or a "skilled mechanic" did work as a that "does not require the exercise of inventive skill."¹²⁴

124. MPEP, *supra* note 4, § 2137.01. Note the circularity.

Inventors may apply for a patent jointly even though (1) they did not physically work together or at the same time, (2) each did not make the same type or amount of contribution, or (3) each did not make a contribution to the subject matter of every claim of the patent.¹²⁵

125. 35 U.S.C. § 116.

That said, two people who work completely independently are not joint inventors. There must have been "some quantum of collaboration or connection." The MPEP gives as examples "collaboration or working under common direction, one inventor seeing a relevant report and building upon it or hearing another's suggestion at a meeting."¹²⁶

126. mpep at 2137.01

Employers and Employees

When an employee creates a patentable invention as part of their job duties, the employee is still the inventor and is still the only person entitled to a patent.¹²⁷ That said, employees are frequently under a contractual duty to cooperate in the employer's efforts to obtain a patent in the employee's name and to assign their rights in the resulting patent to the employer. The important difference in practice is simply that this duty is not the default: if the employer wants rights over employees' inventions, it must specifically require this as part of the employment contract.

If one applicant passes another's work off as their own, that does not make them an inventor. The Patent Act handles such cases with a *derivation* proceeding. The plagiarized applicant can file a petition arguing that "an inventor named in the earlier application derived the claimed invention from an inventor named in the petitioner's application . . . without authorization."¹²⁸ If the PTAB agrees, it can substitute the correct inventors on any application or patent.

127. By contrast, trade secret vests the employer, not the employee, with ownership.

128. 35 U.S.C. § 135(a)(1).

Davis Toys Problem

Your client, the Davis Toys corporation, has developed a working prototype of a wind-up car that dramatically shatters into eight separate pieces when it collides with something, and then can be reassembled easily to repeat the fun. The following people have been involved in some capacity with the production of the prototype:

- Andy Davis, the CEO, who asked the R&D department to "come up with a new action toy concept, maybe something with cars."
- Trixie Schaal, the head of R&D, who proposed the idea of a wind-up car that breaks and can be reassembled.
- Jessie Cusack, a toy designer, who sketched out the spring-loaded latch that causes the doors and hood to fly off when released. Cusack has since left the company under acrimonious circumstances.
- Buzz Allen, another toy designer, who worked up Cusack's sketch into an initial working prototype and oversaw the testing. Allen died of cancer earlier this year.
- Barbie Benson, a toy designer who used the commercially-available off-the-shelf 3D modeling tool Etch to create the precise configuration of eight distinct pieces. Benson input Allen's initial design specification into Etch, which automatically used a complex machine-learning model to refine it into a specific set of parts that could be easily manufactured, while avoiding dangerous features like sharp corners.
- Gabby Hendricks, an eight-year-old, who conducted numerous play-tests with the prototype and showed the Davis employees what worked and what didn't.

- Rex Shawn, an intern, who suggested a design alteration to the latch after the initial version proved too fragile after repeated testing.
- Bo Potts, an artist, who created the red, orange, and white paint scheme on the prototype.

Davis has authorized the prototype for production. It will be shown at toy shows over the next year to gather initial orders.

You are preparing the utility patent application for the toy design. Who should you name as inventor or inventors on the application

2 Priority: Novelty and Statutory Bars

Priority rules determine which of competing claimants is entitled to an IP right based on an earlier claim. It is rarely as simple as “first in time” because what counts as “first” could be assessed in different ways. As we shall see, U.S. patent law mostly creates priority by preventing all but one – or sometimes all – of the potential claimants from obtaining a patent.

Under the present (post-AIA) section 102, an applicant “shall be entitled to a patent unless” someone somewhere has done something that makes the invention not patentable. That something is called a *prior art reference* and it is said to *anticipate* the applicant’s invention. Conceptually, any such rule raises three questions:

- What makes a prior art reference sufficiently *similar* to the applicant’s “claimed invention” to make it unpatentable? If Alfie applies to patent an oven, Beth’s previous work on metalworking is irrelevant to the novelty of Alfie’s oven. Patent law has settled on a remarkably elegant test to capture this idea: the test for anticipation is simply the test for infringement plus the test for enablement. A claim is anticipated by a prior art reference if that reference would infringe the claim. “That which infringes, if later, would anticipate, if earlier.”¹²⁹
- Which kinds of *activities* count as prior art? The present section 102 uses the words “patented, described in a printed publication, or in public use, on sale, or otherwise available to the public.” These phrases are broad, but they do not exhaust the universe of human activity. If Alfie files for a patent on an oven of a type that Beth once built and then demolished without using or telling anyone else, Beth’s secret use does not qualify as prior art and will not stand in the way of Alfie’s application.
- *When* must an activity have taken place to qualify as prior art? The present section 102 uses the words “before the effective filing date of the claimed invention,” so the patent applicant must not only think of the invention and make it work but must also make it to the Patent Office before anyone else goes public with the same idea. If Alfie invents in January and files in March but Beth publishes in February, Alfie is out of luck. This is one of the major

129. *Peters v. Active Mfg. Co.*, 129 U.S. 530, 537 (1889).

changes in the America Invents Act: under pre-AIA law, Alfie’s March application based off a January invention date would have been good enough. As we dig into the text of the AIA, we will see why it is said to create a rule of “first inventor to file.”

Not coincidentally, these are the same kinds of questions one must also ask about *infringement*: what kinds of conduct are prohibited, what makes a defendant’s use too similar, and when does it fall within the term of the plaintiff’s rights? This symmetry is baked into patent law, as it is to many other fields of intellectual property law.

a Anticipation

We start with similarity. A prior art reference anticipates a claim if “each and every element as set forth in the claim is found, either expressly or inherently described” in that reference.¹³⁰ It must be a single reference, so a reference with elements A, B, and C anticipates a claim to A, B, and C, but a pair of references, one with A and B and the other with C, do not.

Every interesting claim covers numerous possible embodiments. It is anticipated by *any* of those embodiments, even one. In *Brown v. 3M*, a patent directed to addressing the Y2K problem claimed a system with data records in “at least one of two-digit, three-digit, or four-digit” formats.¹³¹ It was anticipated by a system that used a two-digit format—just as a system using a two-digit format would have been covered by the claim for infringement purposes. The same is true for a claim to a genus. A claim directed to “an animal” is anticipated by a prior-art reference disclosing a monkey.

In the other direction, a prior-art reference disclosing a genus may or may not anticipate a claim to a species within that genus. A claim to “a monkey” is not anticipated by a prior art reference disclosing other animals, like wolves and horses. It is also not anticipated by a prior art reference disclosing “animals” generically, as there are millions of types of animals. But when the species is clearly named, it doesn’t matter if other species are also named as well. “The tenth edition of the *Merck Index* lists ten thousand compounds. In our view, each and every one of those compounds is [anticipated by the *Merck Index*].”¹³²

As an example of how anticipation works, consider *Titanium Metals Corp. of America v. Banner*.¹³³ In 1974, Titanium Metals applied for a patent on an invention by Loren Covington and Howard Palmer, consisting of an alloy (a mixture of metals) containing mostly titanium (Ti) with small quantities of nickel (Ni), molybdenum (Mo), and iron (Fe). They determined the ranges of these various metals at which the alloy had various useful properties, particularly “corrosion resistance in hot brine.” Thus, their Claim 1 read:

A titanium base alloy consisting essentially by weight of about 0.6% to 0.9% nickel, 0.2% to 0.4% molybdenum, up to 0.2% maximum iron, balance titanium, said alloy being

130. MPEP, *supra* note 4, § 2131.

131. *Brown v. 3M*, 265 F.3d 1349 (Fed. Cir. 2001).

132. *Ex parte A*, 17 U.S.P.Q. 2d 1716 (BPAI 1990).

133. *Titanium Metals Corp. of Am. v. Banner*, 778 F.2d 775 (Fed. Cir. 1985).

characterized by good corrosion resistance in hot brine environments.

The court affirmed the USPTO's rejection of their claim over a three-page 1970 article by S.V. Kalabukhova and V.S. Mikheyev titled *Investigation of the Mechanical Properties of Ti-Mo-Ni Alloys*, published in a Russian scientific journal in 1970. The article contains a graph of the properties of alloys with molybdenum and nickel in a ratio of 1:3, and that graph had a data point for a 1% concentration of the molybdenum plus nickel. Doing out the math, this works out to .25% molybdenum and .75% nickel, both of which fall within the claimed ranges. That made it an anticipating reference, and thus Claim 1 failed.

Titanium Metals argued that the article did not describe the alloy's composition in so many words, which was true. No matter, it clearly disclosed the alloy itself; a POSITA looking at the graph would know that the data point described a mixture of titanium, molybdenum, and nickel matching the ranges in Claim 1's ranges. Titanium Metals also argued that the article said nothing about the alloy's corrosion resistance, which was also true. But the corrosion resistance was an *inherent* property of the alloy. When Kalabukhova and Mikheyev made their alloy, it was corrosion-resistant in hot brine, whether they tested or appreciated this property or not.

This example illustrates the symmetry of anticipation and infringement. If a metallurgist made an alloy in the same proportions described in the article it too would be corrosion-resistant in hot brine. The metallurgist could not defend against an infringement lawsuit by Titanium Metals by arguing, "I didn't know it was corrosion-resistant." It would be corrosion-resistant, whether the metallurgist appreciated it or not, and the same rule applies to anticipation. It falls within the claim terms for both anticipation and infringement purposes.

b Categories of Prior Art

Under post-AIA Section 102(a)(1), "A person shall be entitled to a patent unless the claimed invention was (1) patented, (2) described in a printed publication, or (3) in public use, (4) on sale, or (5) otherwise available to the public before the effective filing date of the claimed invention."¹³⁴ A good rule of thumb is that a document or use by a third party counts as prior art unless it was kept confidential enough to qualify as a trade secret.¹³⁵

1 "patented"

U.S. patents are prior art as of the day they issue, no questions asked, end of story. It does not matter who filed the patent: the inventor or a third party.¹³⁶

It is not always so easy to tell whether a foreign right is a "patent" within the meaning of § 102. For example, *In re Carlson* held that a German industrial design patent (a "Geschmacksmuster") counted as a patent for prior art purposes. At the time, a person could obtain a

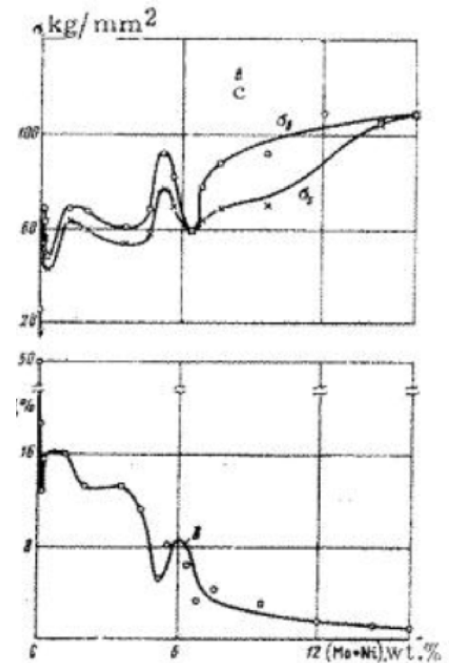

Figure 1c from Kalabukhova and Mikheyev

134. 35 U.S.C. § 102(a)(1) (emphasis and numbering added).

135. See Camilly A. Hrdy & Sharon Sandeen, *The Trade Secret Standard for Prior Art*, 70 AM. U. L. REV. 1269 (2021).

136. If the inventor was also the inventor on the prior patent, they can split off a continuation or divisional application. A patent application is not prior art against itself.

Geschmacksmuster by depositing an application with a drawing, photograph, or sample in a local regional office in Germany. A general description of the design was published, but one had to travel to the regional office to view the design itself. *Held*, this was enough to make one prior art, even though "Geschmacksmuster on display for public view in remote cities in a far-away land may create a burden of discovery for one without the time, desire, or resources to journey there in person or by agent to observe that which was registered and protected under German law."¹³⁷ Such is life.

2 "described in a printed publication"

The emphasis in the "printed publication" test is on on the "public" part of the phrase – whether the information has been shared widely enough that it should be regarded as having been effectively and irrevocably put into the public domain. Again, publications by the inventor themselves count, as do publications by others.

The archetype of a printed publication is a scientific article, like the Kalabukhova/Mikheyev article in *Banner*. Other common printed publications include books, product brochures and manuals, and technical reports. There are three requirements for an alleged prior art reference to be a "printed publication." It must be printed, it must be published, and it must be enabling.

What is "printed" is a straightforward threshold, but do not take the word too literally. Books and papers are printed, of course, but so are web pages, even though they are stored digitally rather than being "printed" on paper. The crucial quality is permanence. In *Regents of the University of California v. Howmedica, Inc.*, one of the inventors gave a lecture describing an artificial knee to a group of about 30 people at a medical association meeting.¹³⁸ His oral descriptions were not a printed publication, and neither were the slides he displayed, because each slide vanished as he proceeded to the next.¹³⁹ In other words, the "printed" part of the printed-publication requirement demands that what is shared publicly must be tangible and persistent.¹⁴⁰

The publication requirement is more pragmatic. It asks, in effect, whether a motivated POSITA could reasonably find it. Once again, the POSITA is the audience of patent law. Learned Hand, in his typically pithy way, described the test as whether a disclosure "goes direct to those whose interests make them likely to observe and remember whatever it may contain that is new and useful."¹⁴¹

Almost anything "published" in the sense that books and articles are traditionally published is sufficiently public. The Kalabukhova/Mikheyev article cited in *Banner* was published in English translation in a journal distributed in the West. But even if it had only been distributed in Russia in its original Russian in Доклады Академии Наук СССР (Металлы) (i.e. the metallurgical journal of the Proceedings of the USSR Academy of Sciences),¹⁴² it would still have been a printed publication. It was available to any member of the public in-



U.S. Des. Pat. No. 289,855: Dual Compartment Bottle or Similar Article

137. *In re Carlson*, 983 F.2d 1032, 1034 (Fed. Cir. 1992).

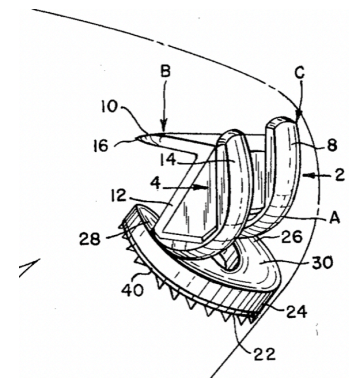

U.S. Pat No. 3,869,731: Articulated Two-Part Prosthesis Replacing the Knee Joint

138. *Regents of the Univ. of Cal. v. Howmedica, Inc.*, 530 F. Supp. 846 (D.N.J. 1981).

139. What about the transparencies – the literal film "slides" – he projected the presentation from?

140. We will meet similar requirements in copyright (fixation), trademark (affixation), and design patent.

141. *Jockmus v. Leviton*, 28 F.2d 812, 813–14 (2d Cir. 1928).

142. This was a prestigious journal, and important enough to be translated, which explains how the article wound up in the prior art search. This random Russian article was less random than it seems.

cluding POSITAs, in a journal widely known among POSITAs to deal with the properties of alloys, and it was in fact distributed to numerous POSITAs.

One line of cases deals with obscure references; they are available for anyone who looks, but it is unclear whether anyone will know where to look. In *In re Cronyn*, three college students' undergraduate thesis were deposited in the Reed College library.¹⁴³ They were held not to be printed publications that anticipated their faculty advisor's patent application, because the thesis were catalogued only on index cards filed alphabetically by author in a shoebox in the chemistry department.¹⁴⁴ But in *In re Hall*, a doctoral dissertation that was indexed in the main Freiburg University library catalogue was a printed publication.¹⁴⁵

Another line of cases deals with documents that are circulated to limited audiences with ambiguous expectations of confidentiality. Internal corporate distributions with standard trade-secret protections (NDAs, confidential stamps, etc.) are not printed publications. But handing out a CD with a video on spinal surgery and a binder with printouts of slides to audiences of 20 and 55 surgeons was a printed publication.¹⁴⁶ An extreme example is *In re Klopfenstein*, where the inventors gave a presentation on preparing foods containing double extruded soy cotyledon fiber to a meeting of the American Association of Cereal Chemists.¹⁴⁷ They printed out their fourteen slides on a poster board, which was on display for two and a half days at the conference. The presentation by itself was not a printed publication, but the poster was. The court discussed factors including: (1) the length of the display (several days), (2) the expertise of the audience (high, as this was a conference in the field), (3) whether there were legal or professional expectations of confidentiality (no), and (4) the ease with which the information could be copied (the crucial advance was contained in only a few bullet points on double versus single extrusion).¹⁴⁸

Finally, a printed publication is only an anticipating prior art reference if it is *enabling*, i.e., it would enable a POSITA to carry out the claimed invention.¹⁴⁹ This makes sense. I should not be able to block all patents on quiet hovercraft by publishing an article saying, "wouldn't it be great if someone invented a quiet hovercraft?" For an example of an enabling printed publication, consider *Banner* again. Titanium Metals tried to argue that the article was not enabling. But there was nothing interesting to enable. Actually making the alloy of titanium, molybdenum, and nickel was not hard. The USPTO's expert testified that he knew at least three different ways to prepare the alloy.¹⁵⁰ Indeed, the patent application itself did not disclose how to make the alloy; it presumed that POSITAs would already know how.¹⁵¹

3 "in public use"

The public-use bar is different for uses by third parties and uses by the inventor themselves. In addition, some uses that are otherwise public do not count if they are necessary to test the invention, under the doctrine

143. *In re Cronyn*, 890 F.2d 1158 (Fed. Cir. 1989).

144. "It was on display in the bottom of a locked filing cabinet stuck in a disused lavatory with a sign on the door saying 'Beware of the Leopard.'" DOUGLAS ADAMS, *THE HITCHHIKER'S GUIDE TO THE GALAXY* (1979). Printed publication?

145. *In re Hall*, 781 F.2d 897 (Fed. Cir. 1986).

146. *Medtronic, Inc. v. Barry*, 891 F.3d 1368 (Fed. Cir. 2018).

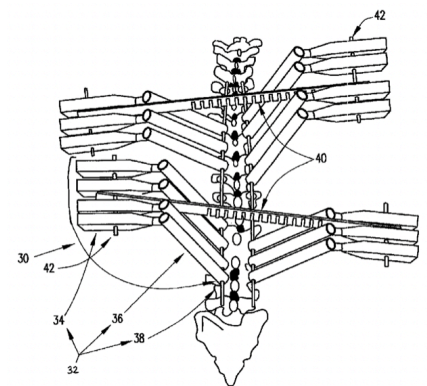

U.S. Pat. No. **7,670,358**: System and Method for Aligning Vertebrae in the Amelioration of Aberrant Spinal Column Deviation conditions.

147. *In re Klopfenstein*, 380 F.3d 1345 (Fed. Cir. 2004).

148. Does this analysis should remind you of the fact-intensive actual-secrecy and reasonable-efforts tests in trade secret? It should.

149. MPEP, *supra* note 4, § 2121.

150. The expert volunteered this information on cross-examination, which raises questions about Titanium Metals's trial strategy.

151. And if not . . . ?

of *experimental use*.

Use by Third Parties

The “public” part of “public use” is important. What would otherwise have been public use by a third party will not be prior art if it has been carried on under conditions of affirmative secrecy sufficient to maintain a trade secret. In *Rosaire v. National Lead Co.*, two patents on searching for oil deposits by taking soil samples were invalidated in light of work previously carried on by a third party, Gulf Oil. “The work was performed in the field under ordinary conditions without any deliberate attempt at concealment or effort to exclude the public and without any instructions of secrecy to the employees performing the work.”¹⁵² In trade-secret terms Gulf Oil was not making reasonable efforts to maintain the secrecy of its drilling techniques. Whether or any member of the public had in fact observed Gulf’s work in sufficient detail to learn how it worked, the fact that Gulf had not made rigorous efforts to exclude them was enough to make that work prior art.

Very occasionally, a third party will have made a use that was public but obscure. This “lost art” is treated as a public use as long as the information about how the invention worked was made public. Thus, in *Coffin v. Ogden*, a reversible door lock (i.e. one that could be installed in doors opening either to the left or to the right) was anticipated by a lock built by Barthol Erbe, who made three copies and demonstrated its workings to several others:

It was known at the time to at least five persons, including Jones, and probably to many others in the shop where Erbe worked; and the lock was put in use, being applied to a door, as proved by Brossi. It was thus tested and shown to be successful.¹⁵³

But in *Gayler v. Wilder*, a fire-proof “salamander safe” with an insulating layer of plaster was patentable. Another inventor, James Conner, had made and used a similar safe previously, but never tested it to confirm that it worked, or documented how it was built. The Supreme Court explained:

For if the Conner safe had passed away from the memory of Conner himself, and of those who had seen it, and the safe itself had disappeared, the knowledge of the improvement was as completely lost as if it had never been discovered. The public could derive no benefit from it until it was discovered by another inventor.¹⁵⁴

The difference is that Erbe both showed his lock to others and demonstrated how it worked, whereas Conner allowed others to see the safe but did not demonstrate its inner workings. So there may be a principle of “lost art,” that public uses do not count when “knowledge of the improvement was as completely lost as if it had never been discovered.”¹⁵⁵

152. *Rosaire v. Nat’l Lead Co.*, 218 F.2d 72, 74 (5th Cir. 1955).

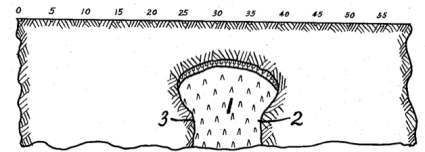

U.S. Pat. No. 2,129,525: Geophysical Prospecting Method

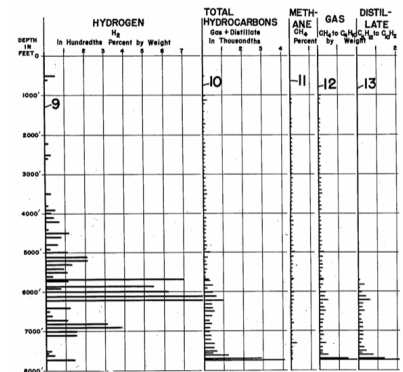

U.S. Pat. No. 2,324,085: Geochemical Well Logging

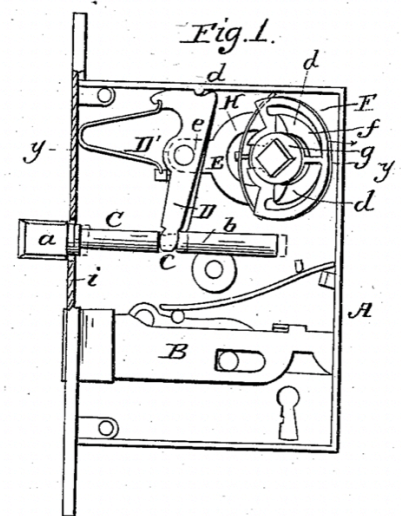

U.S. Pat. No. 32,521: Lock and Knob-Latch

153. *Coffin v. Ogden*, 85 U.S. (18 Wall.) 120, 125 (1874).

Use by the Inventor

The public-use test is different, and draconian, as applied to the inventor's own activities. The reason is that if secret use does not count as public use, an inventor could use the invention in secret for years, and still apply for a patent at any time.¹⁵⁶ The old pre-AIA Section 102 thus distinguished between cases where the invention was "known or used by others" and cases where it was "in public use." While the two provisions differed in their timing (more on this in the Priority section below), the most fundamental distinction was that "known or used by others" only applied to uses made by third parties, whereas "in public use" also could be triggered by anyone, including the inventor. The new post-AIA Section 102 merges these tests, but the difference between uses by others and uses by the inventor remains.

Thus, any commercial use by the inventor, *even a secret one*, is a public use that qualifies as prior art against the inventor's own application. Learned Hand again: "It is a condition upon an inventor's right to a patent that he shall not exploit his discovery competitively after it is ready for patenting. [If he does,] he forfeits his right regardless of how little the public may have learned about the invention."¹⁵⁷ And some of the cases treating the inventor's own activities as public use are extraordinary.

Take *Egbert v. Lippmann*, which involved an invention, developed in 1855, for an improved design of metal corset "springs" or "streels." For a modern analogy, think of the underwire in a bra: a structural element in a foundation garment, typically worn under other clothes, which must be rigid enough to provide support but flexible enough for comfort. Frances Lee and a friend had been complaining that their corset springs frequently broke. The inventor, Samuel Barnes, later Frances's husband, built two sets of more flexible springs by attaching pairs of metal strips with a connecting slot that let them slide a short distance without detaching. She wore them in her corsets for years, and on one occasion Frances and Samuel took the springs out to show a friend how they worked. In 1866, near the end of his life, he applied for a patent, which she tried to enforce after his death.

This, the Supreme Court held, was public use. No matter that the springs were normally hidden from view:

[S]ome inventions are by their very character only capable of being used where they cannot be seen or observed by the public eye. An invention may consist of a lever or spring, hidden in the running gear of a watch, or of a ratchet, shaft, or cog-wheel covered from view in the recesses of a machine for spinning or weaving. Nevertheless, if its inventor sells a machine of which his invention forms a part, and allows it to be used without restriction of any kind, the use is a public one.¹⁵⁸

No matter that Barnes gave, rather than sold, the springs, and no matter



Wilder's Patent Salamander Safe, as described by U.S. Pat. No. 3,117: Improvement in Fire-Proof Chests and Safes

154. *Gayler v. Wilder*, 51 U.S. (10 How.) 477(1851), 498.
155. Alan L. Durham, *Lost Art and the Public Domain*, 49 ARIZ. STATE L.J. 1257 (2017).
156. This ploy only works for certain kinds of technologies. Do you see which ones?
157. *Metallizing Eng'g v. Kenyon Bearing & Auto Parts*, 153 F.2d 516, 520 (2d Cir. 1946).

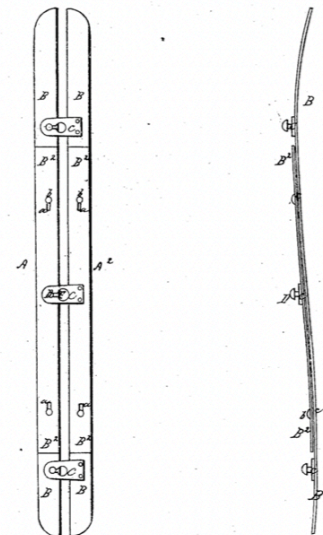

U.S. Pat. No. 56,345: Improvement in Extension Corset-Springs

158. *Egbert v. Lippmann*, 104 U.S. 333, 336 (1881).

that he gave them to his spouse.

They were presented to her for use. He imposed no obligation of secrecy, nor any condition or restriction whatever. They were not presented for the purpose of experiment, nor to test their qualities. . . . The donee of the steels used them for years for the purpose and in the manner designed by the inventor. They were not capable of any other use. She might have exhibited them to any person, or made other steels of the same kind, and used or sold them without violating any condition or restriction imposed on her by the inventor.¹⁵⁹

She did not, but she might have, and that was enough. Egbert was a person *other than the inventor*, so giving her a pair of springs was giving them up to the public.

Previous activity does not trigger the public-use bar unless the invention being used publicly was *ready for patenting*. An invention that has been actually reduced to practice by making it and confirming that it works is ready for patenting. So is an invention that has been constructively reduced to practice by filing a sufficiently disclosed patent application. But an invention can also be ready for patenting when the inventor has prepared “drawings or other descriptions of the invention that [are] sufficiently specific to enable a person skilled in the art to practice the invention.”¹⁶⁰ In other words, if the person *could* file an enabling patent on the basis of the descriptions they have produced, then their work is regarded as far enough along that the public-use bar can apply if they use it publicly. For example, *Pfaff v. Wells Elecs., Inc.* held that a computer chip socket was “ready for patenting” when the inventor’s engineering drawings were sufficient for his manufacturer to begin production.

Experimental Use

The major exception to public use is hinted at in the Supreme Court’s language in *Egbert* that the springs “were not presented for the purpose of experiment, nor to test their qualities. Inventions require work to reduce to practice, and frequently that work requires constructing and testing them under real-world conditions. But the public-use bar would treat these experiments as invalidating prior art. Unlike commercialization, which the inventor can at least plausibly delay, experimentation is necessary *to have something patentable at all.*” Thus, the doctrine of experimental use exempts any disclosures that are necessary to test the invention.

The classic experimental-use case is *City of Elizabeth v. American Nicholson Pavement Co.* Before asphalt became the material of choice for roads, wooden pavement was an occasional alternative to dirt or cobblestones. Samuel Nicholson developed a way of laying down wooden blocks in rows with gravel or tar filling in between. To test how his pavement performed, he paved a 75-foot stretch of a toll road in Boston in 1848, which a private corporation operated. Anyone who rode or

159. *Id.* at 337.

160. *Pfaff v. Wells Elecs., Inc.*, 525 U.S. 55, 67 (1998).

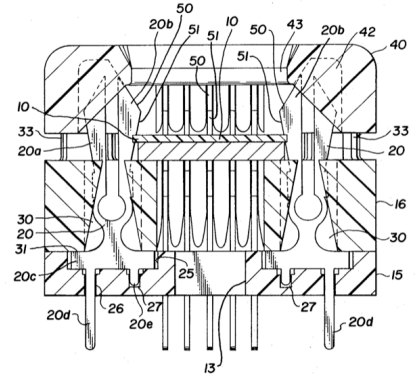

U.S. Pat. No. 4,491,377: Mounting Housing for Leadless Chip Carrier

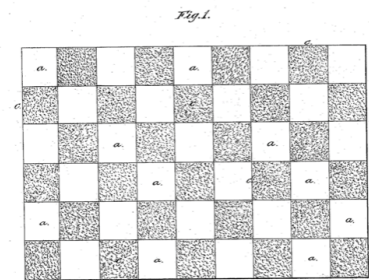
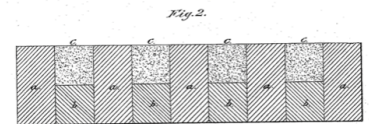

U.S. Pat. No. 11,491: Wood Pavement



Surviving Nicholson wood-block pavement in Philadelphia

drove along the road could see the top layer of the pavement. This would have been a public use under any of the cases above: open to the general public, in plain view, and commercialized. The Court explained:

Now, the nature of a street pavement is such that it cannot be experimented upon satisfactorily except on a highway, which is always public.

When the subject of invention is a machine, it may be tested and tried in a building, either with or without closed doors. In either case, such use is not a public use, within the meaning of the statute, so long as the inventor is engaged, in good faith, in testing its operation. He may see cause to alter it and improve it, or not. His experiments will reveal the fact whether any and what alterations may be necessary. If durability is one of the qualities to be attained, a long period, perhaps years, may be necessary to enable the inventor to discover whether his purpose is accomplished. . . .

Whilst the supposed machine is in such experimental use, the public may be incidentally deriving a benefit from it. If it be a grist-mill, or a carding-machine, customers from the surrounding country may enjoy the use of it by having their grain made into flour, or their wool into rolls, and still it will not be in public use, within the meaning of the law.

But if the inventor allows his machine to be used by other persons generally, either with or without compensation, or if it is, with his consent, put on sale for such use, then it will be in public use and on public sale, within the meaning of the law.¹⁶¹

For a modern example of (failed) experimental use, consider *Lough v. Brunswick Corp.* Steven G. Lough, worked at a marina, designed an improved seal for outboard motors, and built six prototypes in 1986. One he put in his own boat; the others he gave to friends. In 1988, he filed a patent application. The court cited the following factors to evaluate whether a public use is experimental:

[T]he number of prototypes and duration of testing, whether records or progress reports were made concerning the testing, the existence of a secrecy agreement between the patentee and the party performing the testing, whether the patentee received compensation for the use of the invention, and the extent of control the inventor maintained over the testing.¹⁶²

By these standards, Lough's use was not experimental. He kept no records; he did not inspect the seals after use; he did not supervise his friends' use; he failed to keep control over the seals (one was sold by his friend to a stranger); he did not require his friends to maintain confidentiality. The practice point is thus that the problem with Lough's testing

161. *City of Elizabeth v. Am. Nicholson Pavement Co.*, 97 U.S. 126, 134–35 (1878).

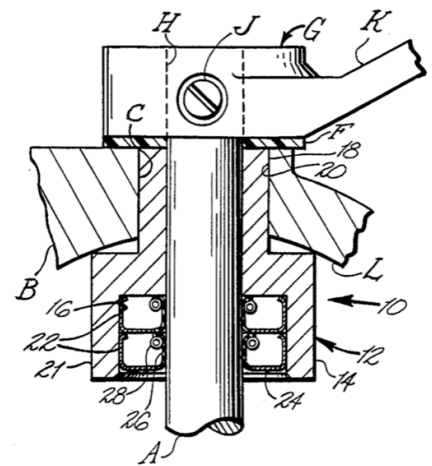

U.S. Pat. No. 4,848,775A: Liquid Seal for Marine Stern Drive Gear Shift Shafts

162. *Lough v. Brunswick Corp.*, 86 F.3d 1113, 1120 (Fed. Cir. 1996).

was not that he gave his friends the invention to test; it was that he failed to maintain “some degree of control and feedback” when he did. Lough had good reason to test his prototypes, but there was no compelling reason he couldn’t have engaged in an organized testing program, rather than just handing out prototypes like candy to his friends.

When does the period of allowable experimental use end? When the invention is reduced to practice – i.e., when the inventor knows that it works for its intended purpose. This makes a certain logical sense; once the invention is known to work, further testing is unnecessary. But it creates a trap for the unwary, because of the uncertainty in the timing about when the invention actually works. If you think that your use is experimental but a court later disagrees, your experimental use is now an invalidating public use.

4 “on sale”

The public-use bar and the on-sale bar are based on similar logic: commercialization. Putting something on sale is a way of commercializing it, just as using it can be.

Most sales are straightforward; if you send me money and I send you the thing, I have sold you the thing. One nuance is that the statute says “on sale” and not just “sold.” As long as I am taking orders – even if I have not started shipping the goods or even manufacturing them in quantity – I have put the thing on sale within the meaning of Section 102. This can require some careful parsing of the dealings between parties. In *Hamilton Beach Brands v. Sunbeam Products*, the purchaser submitted an order for slow cookers with clips to seal the lid on, and the supplier responded with an acknowledgment saying it would begin production on receiving the purchaser’s release. *Held*, on sale.¹⁶³ But in *Linear Tech. Corp. v. Micrel, Inc.*, the purchaser submitted an order and received an acknowledgment reading “WILL ADVISE ON PART # ORDERED–NOT BOOKED”. *Held*, not on sale.¹⁶⁴

Note that the “sale” must be a sale of goods embodying the invention, not a sale of rights in the invention itself (e.g. exclusive rights to market the invention). The line can be tricky where the two are not as obviously distinguishable as they are with ball bearings or snowplows. Thus, a standard “software license” typically triggers the on-sale bar because it comes with a copy of the software itself.¹⁶⁵ The sale need not be public – the statute reads “on sale,” not “on public sale” – so even a secret commercial sale qualifies as prior art.¹⁶⁶

Like public use, the on-sale bar also only applies to inventions that are ready for patenting. *Pfaff* was actually an on-sale case. *Pfaff* sent his engineering drawings to the manufacturer in March 1981, took a written order on April 8, 1981, and filled the order in July 1981. The invention was on sale as of April 8, because it was ready for patenting once he had the engineering diagrams, even though he hadn’t yet made the sockets until later. (This was eleven days too early for *Pfaff*, who filed a patent application on April 19, 1982.)

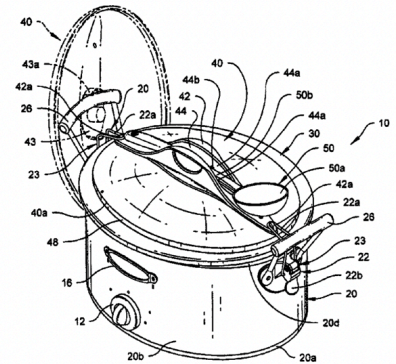

U.S. Pat. No. 7,947,928: Slow Cooker

163. *Hamilton Beach Brands v. Sunbeam Prods.*, 726 F.3d 1370 (Fed. Cir. 2013).

164. *Linear Tech. Corp. v. Micrel, Inc.*, 275 F.3d 1040 (Fed. Cir. 2001).

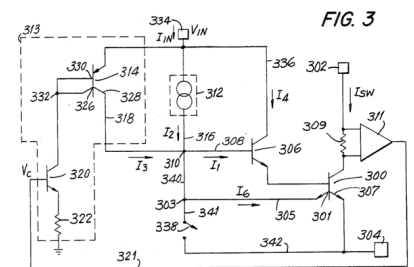

U.S. Pat. No. 4,755,741: Adaptive Transistor Drive Circuit

165. *In re Kollar*, 286 F.3d 1326, 1331 (Fed. Cir. 2002).

166. *Helsinn Healthcare S.A. v. Teva Pharms. USA, Inc.*, 139 S.Ct. 628 (2019).

The on-sale bar can bite inventors who are aggressive in marketing their inventions – or those in industries where the goods are sold up front but production takes a longer time. As with public use, the rationale has as much to do with encouraging inventors to file promptly as it does with testing whether the public actually has the knowledge disclosed in the patent.

5 "otherwise available to the public"

The old Section 102 had a closed list of prior art categories. The open-ended language "otherwise available to the public" is new with the AIA. In the PTO's view:

This "catch-all" provision permits decision makers to focus on whether the disclosure was "available to the public," rather than on the means by which the claimed invention became available to the public or whether a disclosure constitutes a "printed publication" or falls within another category of prior art.¹⁶⁷

167. MPEP, *supra* note 4, § 2152.02(e).

Prior Art Questions

1. Suppose that the Liu presentation had not been shown at the AACC meeting but instead been posted to Liu's personal webpage. Printed publication? What if Liu had emailed it to a mailing list for cereal chemists? Are there further questions you would want to ask before committing to an answer on either of these hypotheticals?
2. Is there a claim that the patentee's counsel in *Banner* could have drafted that would have captured the newly-discovered properties of the alloy (corrosion resistance in hot brine) without being anticipated by (Kalabukhova and Mikheyev 1970)?
3. From 1960 to 1972, the Acme Corporation sold the Bait-o-Matic, a grey egg-shaped plastic container containing sharp-grained sand with a grain size of 1/25 of an inch designed to be used to immobilize earthworms. Which claims, if any, of the Lukehart worm-immobilizing patent are invalid because they were anticipated by the Bait-o-Matic?

c Priority

Now that we know what counts as a prior art reference, and whether a prior art reference anticipates a claim, we can consider the intricate (but not as intricate as they used to be) rules that govern *when* a reference comes before a claim so as to anticipate it.

The AIA's novelty provisions took effect on March 16, 2013. They apply to any applications filed on or after that date. Applications filed before that date are examined under the old pre-AIA rules. 2013 is far

enough in the rear-view mirror that it is no longer important – at least in a IP survey – to learn the details of the pre-AIA “first to invent” system. It is still useful to know the basics of how it worked, because it sheds light on how the post-AIA “first inventor to file” system works.

1 Pre-AIA

Under the old Section 102:

A person shall be entitled to a patent unless –

- (a) the invention was [prior art by someone else] before the invention thereof by the applicant for patent, or
- (b) the invention was [prior art by anyone] more than one year prior to the date of the application for patent, or . . .
- (g) before such person’s invention thereof, the invention was made by another inventor who had not abandoned, suppressed, or concealed it. . . .

Old Section 102(a) was a *novelty* provision: it denied a patent where someone else engaged in activity showing that the applicant’s invention was not novel when it was supposedly “invented.” Old Section 102(b) was a *statutory bar*: it denied a patent to an applicant who waited too long to apply. And old Section 102(g) was a true *priority* provision that dealt with the not-uncommon situation in which two parties independently came up with the same invention and neither of them generated prior art that would block the other’s application.

All three of these ruled turned on when the applicant *invented* (i.e. conceived). Unlike the date that someone filed paperwork with the USPTO, establishing the date of invention requires a backward-looking evidentiary process. Lab notebooks, timestamps, correspondence, and other documents were all relevant and fair game. And it is not as though “the formation in the mind of the inventor of a definite and permanent idea of the complete and operative invention” is an event that definitely exists in the world and can easily be localized in time.

Making matters even messier, the old Section 102(g) explicitly required the USPTO to consider the “reasonable diligence” of an inventor who was first to conceive but second to file. Section 102(g) came in to play when multiple pending applications with different inventors were directed to overlapping inventions. The USPTO would initiate an *interference* proceeding in which the competing applicants would present evidence of their conception dates and diligence in reducing to practice. In particular, the second inventor would prevail if the

An old case, *Morway v. Bondi*, shows some of the involved intricacies. It involved competing applications for a grease containing polyethylene glycol as an additive.¹⁶⁸ A timeline will be helpful:

- Morway conceived on or before April 12, 1945.¹⁶⁹
- Bondi conceived on June 14, 1945.
- Bondi filed on October 31, 1945.

¹⁶⁸ *Morway v. Bondi*, 203 F.2d 742 (CCPA 1953).

¹⁶⁹ Why doesn’t it matter whether it was “on” or “before” April 12?

- Morway filed on December 27, 1946.

This timeline made Morway the first inventor, which meant that it was entitled to a patent if it reduced to practice first. Bondi's October 31, 1945 filing date constituted constructive reduction to practice, so Morway needed to beat that date. It argued that on January 30, 1945 it subjected a sample of the grease to an oxidation test with good results (and hence knew that the grease would work). But the court disagreed; "the Norma-Hoffman bomb test merely measures resistance of the grease to oxidation under static or storage conditions, but not under service conditions," so it "[f]ar short of simulating actual service tests with sufficient closeness to constitute a reduction to practice."¹⁷⁰ But the court still had to consider reasonable diligence, and its discussion is worth quoting at length to show the kinds of rabbit holes that this inquiry could descend into.

170. *Morway*, 203 F.2d at 746.

Morway v. Bondi
203 F.2d 742 (CCPA 1953)

Thus, appellants, although first to conceive, were last to reduce to practice. If they are to prevail, they must affirmatively establish continuing and reasonable diligence in reducing to practice or reasonable excuse for failure to act. Such diligence must be shown from a date immediately prior to the time that Bondi conceived, on June 14, 1945, until reduction to practice by themselves as first conceivers.

The record shows the following activities by appellants:

- On June 7, August 1, August 15, and September 28, 1945, greases meeting the counts were prepared, and laboratory tests, such as the A.S.T.M. penetration test, were conducted on them.
- On October 2, 1945, Miss O'Halloran conducted a Ford Wheel Bearing Test on the grease prepared September 28.
- On December 26, 1945, a grease meeting the counts was prepared, and laboratory tests conducted on it.
- The record then shows further activities (mainly aimed at possible commercial exploitation of the grease in issue) in February, May, August, and November of 1946.

There was no activity at all between June 7 and August 1, 1945, thereby creating a hiatus of one and one-half months right at the outset of the critical period when Bondi entered the field. There is a further hiatus of one and one-half months, during the early part of the critical period, from August 15 to September 28, 1945, when there was no activity at all by Morway et al. It seems manifest from the above chronology that the activities by Morway et al. from early June 1945 to December 1946 were quite sporadic throughout that period.

In our opinion, the foregoing activities by appellants do not constitute reasonable diligence in reducing the invention to practice during the critical period.

Appellants have introduced testimony to the effect that the joint inven-

tors herein and other assisting members of the research team which developed the grease of the issue counts had many other projects and duties. For example, there is testimony indicating that Mr. Morway's primary assignment at the time in question was the development of a carbon black lubricant; and that Mr. Beerbower's primary assignment was the development of a continuous process for manufacturing greases. When the party first to conceive voluntarily lays aside his inventive concept because he is engrossed in pursuit of other projects, this is generally not an acceptable excuse for failure to act diligently in reducing to practice. Clearly there may be circumstances creating exceptions to this rule, but we find no such circumstances in this record.

Morway et al. also seek to explain their lack of diligence by reference to wartime assignments which allegedly took first call on their time. In proper cases, war activities may reasonably excuse the first conceiver's failure to act diligently, but lack of diligence is not excused by a mere assertion that the applicant was engaged in war work. We fail to find in the record before us adequate evidence of such war activities as would excuse appellants' lack of reasonable diligence.

2 Post-AIA

The new Section 102 is beautifully simple, at least compared with what it replaced:

- (a) A person shall be entitled to a patent unless—
 - (1) the claimed invention was [prior art] before the effective filing date of the claimed invention; or
 - (2) the claimed invention was described in a [published patent or application that] names another inventor and was effectively filed before the effective filing date of the claimed invention.
- (b) *Exceptions.* —
 - (1) A disclosure made 1 year or less before the effective filing date of a claimed invention shall not be prior art to the claimed invention under subsection (a)(1) if—
 - (A) the disclosure was made by the inventor [or their collaborator] . . . ; or
 - (B) the subject matter disclosed had, before such disclosure, been publicly disclosed by the inventor [or their collaborator]¹⁷¹

171. patent102

The heart of the change is in Section 102(a)(1): instead of rejecting an application when there was prior art before the applicant's *date of invention*, it rejects the application when there was prior art before the applicant's *date of filing*. A filing date is simple and easy to check. All the lab notebooks and correspondence can be tossed in the metaphorical trash; they are no longer needed to establish the date of conception or reasonable diligence.

Section 102(a)(2) then applies the same logic to priority between competing applications. Whichever has the earlier effective filing date

has priority as against the other. Almost all of *Morway* is irrelevant; Bondi filed first, end of story. (Same result, but with much less effort.)

The AIA's proponents described it as harmonizing the United States with the rest of the world, where priority is assessed strictly on a first-to-file basis. But it qualifies the first-to-file rule in two important ways. First, Section 102(b)(1)(A) exempts *the inventor's own* disclosures for a year. If you publish a white paper on your invention on January 8, 2025 and file an application on January 8, 2026 your white paper is a "disclosure made 1 year or less" and is not prior art as against your application. But if you wait one more day to file, until January 9, 2026, the white paper is prior art and your invention is now forever barred.

Second, Section 102(b)(1)(B) provides that the inventor's own disclosures preempt *anyone else's* disclosure of the same material. That is, once your white paper on January 8, 2025 starts the one-year clock ticking, no one else can undercut your ability to file for a patent by releasing their own white paper on July 8. In effect, under the AIA, the first public disclosure of an invention (1) immediately bars anyone else from patenting the invention, and (2) starts a one-year clock ticking on the discloser's own ability to apply for a patent.

This system is not quite as rigid or as easy to apply as a true first-to-file system. But many groups who work with small and individual inventors argued that a pure first-to-file system is excessively harsh on inventors who may not have the resources to reduce their inventions to practice quickly and who may not be well advised on how to avoid making invalidating disclosures. The one-year grace period was considered a necessary compromise to secure passage of the AIA.

A word of warning. As a counsel to inventors, do not rely on the grace period! It is not good practice to make a disclosure, assume that you have now held your place in line, and wait most of a year before filing. There might be other disclosures you don't know about. Better practice is to file before disclosing anything. Just because (you think there's) a safety net beneath doesn't mean you should jump off a tightrope.

Pleistocene Park Problem

Two biotechnology firms, Crichton Industries and Spielberg Genetics, have been attempting to clone a woolly mammoth (an elephant-like mammal that became extinct about 3,500 years ago) from scattered preserved DNA fragments. The teams made only slow progress at first; the available mammoth DNA fragments were too short and too numerous to combine into a complete DNA sequence using standard laboratory techniques.

Then, on January 1, 2004, mathematician Rube Goldblum published an academic paper describing efficient ways to arrange books in libraries. Crichton's lead researcher read the paper on February 2, 2005 and realized that the method Goldblum was describing could be used to arrange DNA fragments and compile complete DNA sequences.

Goldblum published (on March 3, 2006), a follow-up academic paper explaining how to apply his book-sorting method to the problem of DNA compilation. An executive at Spielberg read the paper on April 4, 2007, and decided to try the technique on the woolly mammoth problem.

On May 5, 2013, in a Crichton laboratory, a modern elephant implanted with a woolly mammoth embryo using standard artificial insemination techniques gave birth to a live woolly mammoth. On June 6, 2013, a Spielberg elephant successfully gave birth to a woolly mammoth. Because both teams started from the same, publicly available sets of woolly mammoth DNA fragments, their DNA sequences were identical. The next day, June 7, 2013, Spielberg held a press conference to announce the birth; it showed video of the baby mammoth and its scientists passed out CDs with the DNA sequence.

On July 12, 2013, Spielberg filed a patent application claiming “a woolly mammoth, having the DNA sequence ...” Crichton filed its own patent application on August 20, 2013 with an identical claim.

Which application, if either, should the PTO allow, and why? Would the answer be different under the old § 102?

3 Nonobviousness

Nonobviousness is just like novelty, only more so. It is described in Section 103:

A patent for a claimed invention may not be obtained, notwithstanding that the claimed invention is not identically disclosed as set forth in section 102, if the differences between the claimed invention and the prior art are such that the claimed invention as a whole would have been obvious before the effective filing date of the claimed invention to a person having ordinary skill in the art to which the claimed invention pertains. Patentability shall not be negated by the manner in which the invention was made.¹⁷²

172. 35 U.S.C. § 103

As an initial example of obviousness, Claim 3 in the patent in *Banner* read:

A titanium base alloy as set forth in Claim 1 having 0.8% nickel, 0.3% molybdenum, up to 0.1% maximum iron, balance titanium.

Where Claim 1 applied to a range of nickel and molybdenum concentrations, Claim 3 narrowed those ranges down to specific values. These values were different than the ones in the Kalabukhova/Mikheyev article (0.75% nickel and 0.25% molybdenum), so they were not anticipated under Section 102. But

The proportions are so close that prima facie one skilled in the art would have expected them to have the same properties. Appellee produced no evidence to rebut that prima

facie case. The specific alloy of claim 3 must therefore be considered to have been obvious from known alloys.¹⁷³

The nonobviousness test differs in three ways from the novelty test.

First, whereas anticipation under novelty requires that every element in a claim be present in a *single* prior art reference, an invention can be obvious in light of *multiple* prior art references. A claim to A, B, and C is novel over a reference having A and B and over a reference having B and C, but it may be obvious in light of the combination of the two.

Second, whereas anticipation is automatic and mandatory if a suitable prior art reference exists, the process of combining prior art references under obviousness is more complicated. Sometimes it is appropriate to combine A+B and B+C to make A+B+C; sometimes it is not. Indeed, the problem of combining references is arguably the defining issue in obviousness.

Third, whereas prior art references in any technical field can support anticipation, prior art for obviousness purposes is restricted to the “analogous arts.” These are technical fields that are related to the problem the PHOSITA is trying to solve.¹⁷⁴

a Overview

The basic idea of obviousness, dating back to 1851’s *Hotchkiss v. Greenwood*, is the a distinction between “an ordinary mechanic acquainted with the business” (in modern terms, a PHOSITA) and a true “inventor.”¹⁷⁵ For a patent to issue, the invention must display “that degree of skill and ingenuity which constitute essential elements of every invention.”¹⁷⁶ The knowledge and skill of the PHOSITA in a field sets a baseline – a baseline that includes inventions that are new but obvious – and only inventions rising above that baseline are patentable.

Recurring classes of innovations that make an invention nonobvious include:

- Finding a needle in a haystack (e.g., a specific fibrous material that works as a light-bulb filament).
- Combining existing things to make something better than either alone (e.g., mixing chocolate and peanut butter).
- Discovering an entirely new phenomenon (e.g., semiconductors).
- Solving a known problem in a new way (e.g., a measuring cup whose gradations are read from above).

Why require nonobviousness? One answer, more explanation than reason, is a cultural ideal of romantic inventorship that thinks of inventors as lone geniuses making big advances entirely on their own and disdains smaller and more routine innovations. Another is a generic skepticism of patents. The higher the obviousness bar is set, the fewer patents that will issue. A stronger version of this argument is that a high nonobviousness bar allows for fewer but broader patents. If many obvious inventions are weeded out, the nonobvious inventions that issue as

173. *Titanium Metals Corp. of Am. v. Banner*, 778 F.2d 775, 783 (Fed. Cir. 1985).

174. PHOSITA with an H.

175. *Hotchkiss v. Greenwood*, 52 U.S. (11 How.) 248, 267 (1851).

176. *Id.*

patents will capture more value and be less encumbered by incremental improvement patents. And an idea tied to patent's theory of invention is that PHOSITAs will generate obvious innovations without requiring patent incentives. Thus, the reward of a patent, with its attendant social costs, should be reserved for extraordinary, nonobvious innovations that would not otherwise take place.

Unlike anticipation, which involves a (relatively) straightforward comparison between a reference and a claim, obviousness is more standard than rule. To say that an invention is obvious is like saying that a defendant's conduct was negligent. A reasonable person's standard of care is defined by what negligence law says, and a PHOSITA's level of skill is defined by what obviousness law says. The only way to get a good sense of what is obvious is to read a lot of cases.

The threshold of nonobviousness has also risen and fallen with time. The Supreme Court in the decades before the 1952 Patent Act was notoriously skeptical of patents. Justice Douglas, in particular, criticized the issuance of patents for "gadgets that obviously have had no place in the constitutional scheme of advancing scientific knowledge."¹⁷⁷ In *Cuno Engineering Corp. v. Automatic Devices Corp.*, he held for the Court that nonobviousness requires that an invention "must reveal the flash of creative genius, not merely the skill of the calling."¹⁷⁸

Congress turned the dial back in the other direction with Section 103's language that "Patentability shall not be negated by the manner in which the invention was made," repudiating any suggestion that nonobviousness requires that the inventor have a "flash of creative genius" in a single instant.¹⁷⁹ The § 103 standard – while still higher than what a PHOSITA would consider obvious – is attainable by mere mortals.

The Supreme Court laid out the modern doctrinal obviousness framework in *Graham v. John Deere Co.*:

Under § 103, the scope and content of the prior art are to be determined; differences between the prior art and the claims at issue are to be ascertained; and the level of ordinary skill in the pertinent art resolved. Against this background the obviousness or nonobviousness of the subject matter is determined. Such secondary considerations as commercial success, long felt but unsolved needs, failure of others, etc., might be utilized to give light to the circumstances surrounding the origin of the subject matter sought to be patented.¹⁸⁰

Graham itself involved a patent on an easy-to-visualize plow attachment with relatively few moving parts. The entire plow is pulled to the right (by a tractor, not shown) to churn up the soil in preparation for planting. At the bottom is the plow tip – a "chisel" – that rips through the soil. Sometimes the chisel hits a rock or other obstructions, in which case the curved piece attached to it – the plow "shank" – is forced backwards to the left.

William T. Graham, the plaintiff, had previously obtained a patent

177. *Great Atl. & Pac. Tea Co. v. Supermarket Equip. Corp.*, 340 U.S. 147, 156 (1950) (Douglas, J. concurring). Is it obvious to a PHOSITA?

178. *Cuno Eng'g Corp. v. Automatic Devices Corp.*, 314 U.S. 84, 91 (1941).

179. Does the definition of inventorship as conception impose its own requirement of instantaneous insight?

180. *Graham v. John Deere Co.*, 383 U.S. 1, 17–18 (1966).

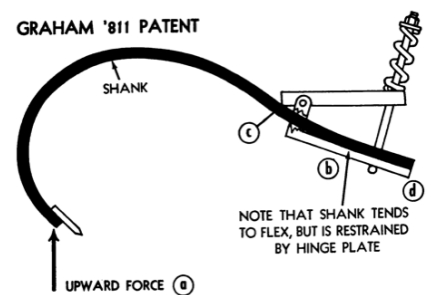
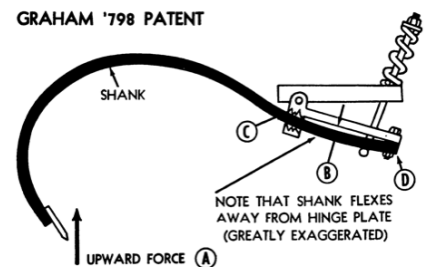

Graham's improved '798 patent (top) and the prior art '811 patent (bottom)

(No. 2,493,811) on a device keep the shank from breaking under the stress of being pulled against rocks. In that patent, the shank is attached to a “hinge plate” with a spring, so that the shank could bounce back to the left and then be pulled to the right by the spring. In a later patent (No. 2,627,798), Graham reversed the position of the shank and hinge plate, so that the shank was attached to the bottom of the hinge plate rather than the top.

The question (slightly simplified) was whether this modification was obvious. Graham argued at length that the new design was better because it let the shank flex along its entire length. In the '811 design, the shank was held tightly in place at the rear of the hinge plate, leading to stress at the point of attachment and damage to the plow frame above it. Free flexing avoided these problems.

But this modification, the Supreme Court held, was obvious:

If free-flexing, as petitioners now argue, is the crucial difference above the prior art, then it appears evident that the desired result would be obtainable by not boxing the shank within the confines of the hinge. The only other effective place available in the arrangement was to attach it below the hinge plate and run it through a stirrup or bracket that would not disturb its flexing qualities. Certainly a person having ordinary skill in the prior art, given the fact that the flex in the shank could be utilized more effectively if allowed to run the entire length of the shank, would immediately see that the thing to do was what Graham did, *i.e.*, invert the shank and the hinge plate.¹⁸¹

Read that slowly and *look at the diagram*. Justice Clark’s opinion identifies a *motivation* for a PHOSITA to make the claimed modification. The problem Graham identified was a real one, but a PHOSITA, observing that problem, would naturally be led to the same invention.

b Combining References

As noted above, a recurring problem in nonobviousness analysis is when to combine two references. Given chocolate and peanut butter, is a Reese’s cup obvious? Many of the classic Supreme Court cases fit this this pattern. In *Hotchkiss*, it was obvious to take an existing door-knob design and make the doorknob itself out of clay or porcelain.¹⁸² In *Reckendorfer v. Faber*, it was obvious to attach an eraser to the end of a pencil by cutting a groove in the pencil.¹⁸³

Writing the same year as *Graham*, Judge Giles S. Rich (one of the two principal drafters of the 1952 Act), summarized the obviousness analysis in a picturesque metaphor:

We think the proper way to apply the 103 obviousness test to a case like this is to first picture the inventor as working in his shop with the prior art references – which he is presumed to know – hanging on the walls around him. One

181. *Id.* at 24–25.

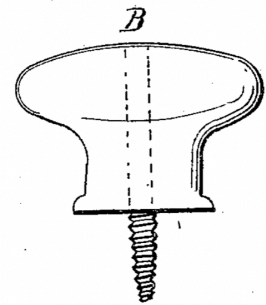

U.S. Pat. No. 2,197: Making Door and Other Knobs of All Kinds of Clay Used in Pottery and of Porcelain

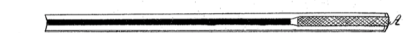
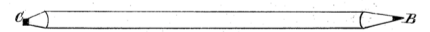

U.S. Pat. No. 19,783: Combination of Lead-Pencil and Eraser

182. *Hotchkiss v. Greenwood*, 52 U.S. (11 How.) 248 (1851).

183. *Reckendorfer v. Faber*, 92 U.S. 347 (1876).

then notes that what applicant Winslow built here he admits is basically a Gerbe bag holder having air-blast bag opening to which he has added two bag retaining pins. If there were any bag holding problem in the Gerbe machine when plastic bags were used, their flaps being gripped only by spring pressure between the top and bottom plates, Winslow would have said to himself, "Now what can I do to hold them more securely?" Looking around the walls, he would see Hellman's envelopes with holes in their flaps hung on a rod. He would then say to himself, "Ha! I can punch holes in my bags and put a little rod (pin) through the holes. That will hold them! After filling the bags, I'll pull them off the pins as does Hellman. Scoring the flap should make tearing easier."¹⁸⁴

After its creation, the Federal Circuit gradually talked itself into a *teaching, suggestion, or motivation* (TSM) test for obviousness, under which a combination is not obvious unless there is "some objective teaching in the prior art or that knowledge generally available to one of ordinary skill in the art would lead that individual to combine the relevant teachings of the references."¹⁸⁵ But in the absence of an explicit suggestion, one would not be implied. This rule produced absurdities like *In re Dembiczak*, in which a leaf bag decorated to look like a jack-o-lantern was nonobvious (for a *utility* patent!) because no prior art reference suggested putting facial features on a lawn bag.¹⁸⁶ And it rejected the idea that "common sense" could fill in a for a missing TSM. In *Arendi S.A.R.L. v. Apple, Inc.*, it held, "Appellees have failed to show why it would be common sense for the 'Add to address book' function to operate by first searching for entries with the same telephone number."¹⁸⁷

The Supreme Court took an obviousness case again in *KSR Intern. Co. v. Teleflex Inc.* Justice Kennedy's opinion acknowledged that while the TSM test "captured a helpful insight," it should not be treated as a "rigid and mandatory formula[]." ¹⁸⁸ For one thing, a combination might be obvious even if the prior art is silent on the point. "The analysis need not seek out precise teachings directed to the specific subject matter of the challenged claim, for a court can take account of the inferences and creative steps that a person of ordinary skill in the art would employ."¹⁸⁹ For another, the PHOSITA's motivation might come from the problem itself. "When there is a design need or market pressure to solve a problem and there are a finite number of identified, predictable solutions, a person of ordinary skill has good reason to pursue the known options within his or her technical grasp."¹⁹⁰

KSR puts a strong emphasis on *synergy* and *unpredictability* as indicators of obviousness. "A court must ask whether the improvement is more than the predictable use of prior art elements according to their established functions."¹⁹¹ This is not a new theme. As the Court explained in *Reckendorfer* in 1876:

184. *In re Winslow*, 365 F.2d 1017, 1020 (C.C.P.A. 1966).

185. *Tec Air, Inc. v. Denso Mfg. Mich. Inc.*, 192 F.3d 1353, 1359 (Fed. Cir. 1999).

186. *In re Dembiczak*, 175 F.3d 994 (Fed. Cir. 1999).



An embodiment of the invention of a lawn bag with a jack-o-lantern face

187. *Arendi S.A.R.L. v. Apple, Inc.*, 832 F.3d 1355, 1365 (Fed. Cir. 2016).

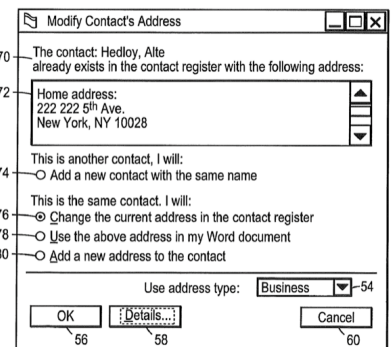

U.S. Pat. No. 7,917,843: Method, System and Computer Readable Medium for Addressing Handling from a Computer Program

188. *KSR Intern. Co. v. Teleflex Inc.*, 550 U.S. 398, 418–19 (2007).

189. *Id.* at 418.

190. *Id.* at 421.

191. *Id.* at 417.

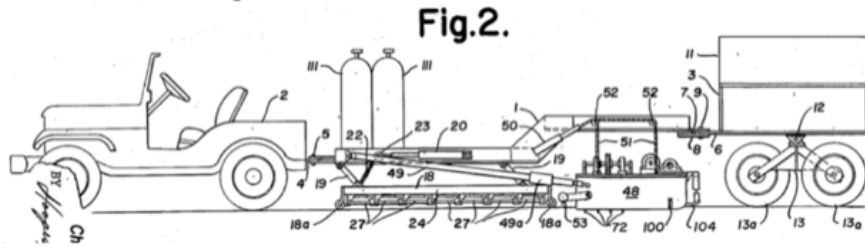

U.S. Pat. No. 3,055,280: Means for Treating Bituminous Pavement

The instruments placed upon the same rod [a pencil and an eraser] might be more convenient for use than when used separately. Each, however, continues to perform its own duty, and nothing else. No effect is produced, no result follows, from the joint use of the two.¹⁹²

Similarly, in *Anderson's-Black Rock, Inc. v. Pavement Salvage Co.*, it was obvious to take a standard paving machine and put a burner on it to heat up the adjacent strip of asphalt.

The device, the Court concluded, did not create some new synergy. The radiant-heat burner functioned just as a burner was expected to function; and the paving machine did the same. The two in combination did no more than they would in separate, sequential operation.¹⁹³

On the other hand, in *United States v. Adams* (“*U.S. v. Adams*”), it was not obvious to build a battery using electrodes made of magnesium and cuprous chloride, rather than zinc and silver chloride.¹⁹⁴

When Adams designed his battery, the prior art warned that risks were involved in using the types of electrodes he employed. The fact that the elements worked together in an unexpected and fruitful manner supported the conclusion that Adams’s design was not obvious to those skilled in the art.

That is, in *U.S. v. Adams*, the prior art affirmatively taught *away* from the combination.

Justice Kennedy’s *KSR* opinion also provides some memorable quotes on the nature of creativity and invention. “A person of ordinary skill is also a person of ordinary creativity, not an automaton.”¹⁹⁵ “[I]nventions in most, if not all, instances rely upon building blocks long since uncovered, and claimed discoveries almost of necessity will be combinations of what, in some sense, is already known.”¹⁹⁶ The opinion closes with a trademark swelling Kennedy peroration:

We build and create by bringing to the tangible and palpable reality around us new works based on instinct, simple logic, ordinary inferences, extraordinary ideas, and sometimes even genius. These advances, once part of our shared knowledge, define a new threshold from which innovation

192. *Reckendorfer v. Faber*, 92 U.S. 347, 356 (1876).

193. *KSR*, 550 U.S. at 417.

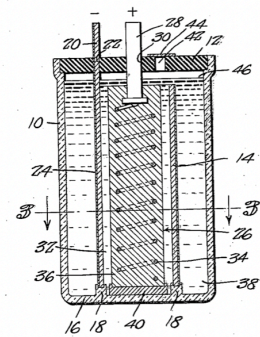

U.S. Pat. No. 2,322,210: Battery

194. *United States v. Adams* (“*U.S. v. Adams*”), 383 U.S. 39 (1966).

195. *KSR*, 550 U.S. at 421.

196. *Id.* at 418.

starts once more. And as progress beginning from higher levels of achievement is expected in the normal course, the results of ordinary innovation are not the subject of exclusive rights under the patent laws. Were it otherwise patents might stifle, rather than promote, the progress of useful arts.¹⁹⁷

KSR's actual discussion of the patent in suit is worth quoting at length. It provides a good example of how to do an obviousness analysis, and you should be exposed to at least one in the course of your studies.

KSR Intern. Co. v. Teleflex Inc.
550 U.S. 398 (2007)

The patent at issue, United States Patent No. 6,237,565 B1, is entitled "Adjustable Pedal Assembly With Electronic Throttle Control." Supplemental App. 1. The patentee is Steven J. Engelgau, and the patent is referred to as "the Engelgau patent." Claim 4 of the Engelgau patent describes a mechanism for combining an electronic sensor with an adjustable automobile pedal so the pedal's position can be transmitted to a computer that controls the throttle in the vehicle's engine.¹⁹⁸

Background

In car engines without computer-controlled throttles, the accelerator pedal interacts with the throttle via cable or other mechanical link. The pedal arm acts as a lever rotating around a pivot point. In a cable-actuated throttle control the rotation caused by pushing down the pedal pulls a cable, which in turn pulls open valves in the carburetor or fuel injection unit. The wider the valves open, the more fuel and air are released, causing combustion to increase and the car to accelerate. When the driver takes his foot off the pedal, the opposite occurs as the cable is released and the valves slide closed.

In the 1990's it became more common to install computers in cars to control engine operation. Computer-controlled throttles open and close valves in response to electronic signals, not through force transferred from the pedal by a mechanical link. Constant, delicate adjustments of air and fuel mixture are possible. The computer's rapid processing of factors beyond the pedal's position improves fuel efficiency and engine performance.

For a computer-controlled throttle to respond to a driver's operation of the car, the computer must know what is happening with the pedal. A cable or mechanical link does not suffice for this purpose; at some point, an electronic sensor is necessary to translate the mechanical operation into digital data the computer can understand.

Before discussing sensors further we turn to the mechanical design of the pedal itself. In the traditional design a pedal can be pushed down or released but cannot have its position in the footwell adjusted by sliding the pedal forward or back. As a result, a driver who wishes to be closer or farther from the pedal must either reposition himself in the driver's seat or move the seat in some way. In cars with deep footwells these are imperfect solutions

197. *Id.* at 427.

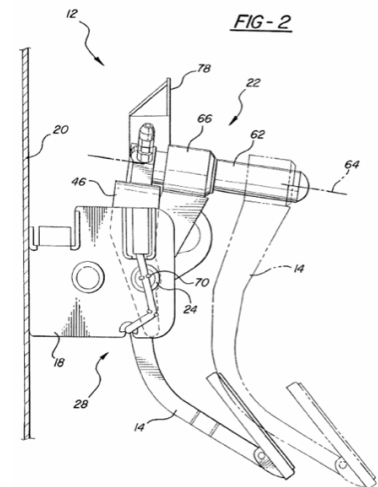

U.S. Pat. No. **6,237,565 B1**: Adjustable Pedal Assembly with Electronic Throttle Control

198. The internal headers are my summaries, not the Supreme Court's.

for drivers of smaller stature. To solve the problem, inventors, beginning in the 1970's, designed pedals that could be adjusted to change their location in the footwell. Important for this case are two adjustable pedals disclosed in U.S. Patent Nos. 5,010,782 (filed July 28, 1989) (Asano) and 5,460,061 (filed Sept. 17, 1993) (Redding). The Asano patent reveals a support structure that houses the pedal so that even when the pedal location is adjusted relative to the driver, one of the pedal's pivot points stays fixed. The pedal is also designed so that the force necessary to push the pedal down is the same regardless of adjustments to its location. The Redding patent reveals a different, sliding mechanism where both the pedal and the pivot point are adjusted.

We return to sensors. Well before Engelgau applied for his challenged patent, some inventors had obtained patents involving electronic pedal sensors for computer-controlled throttles. These inventions, such as the device disclosed in U.S. Patent No. 5,241,936 (filed Sept. 9, 1991) ('936), taught that it was preferable to detect the pedal's position in the pedal assembly, not in the engine. The '936 patent disclosed a pedal with an electronic sensor on a pivot point in the pedal assembly. U.S. Patent No. 5,063,811 (filed July 9, 1990) (Smith) taught that to prevent the wires connecting the sensor to the computer from chafing and wearing out, and to avoid grime and damage from the driver's foot, the sensor should be put on a fixed part of the pedal assembly rather than in or on the pedal's footpad.

In addition to patents for pedals with integrated sensors inventors obtained patents for self-contained modular sensors. A modular sensor is designed independently of a given pedal so that it can be taken off the shelf and attached to mechanical pedals of various sorts, enabling the pedals to be used in automobiles with computer-controlled throttles. One such sensor was disclosed in U.S. Patent No. (filed Dec. 18, 1992) ('068). In 1994, Chevrolet manufactured a line of trucks using modular sensors attached to the pedal support bracket, adjacent to the pedal and engaged with the pivot shaft about which the pedal rotates in operation.

The prior art contained patents involving the placement of sensors on adjustable pedals as well. For example, U.S. Patent No. 5,819,593 (filed Aug. 17, 1995) (Rixon) discloses an adjustable pedal assembly with an electronic sensor for detecting the pedal's position. In the Rixon pedal the sensor is located in the pedal footpad. The Rixon pedal was known to suffer from wire chafing when the pedal was depressed and released.

This short account of pedal and sensor technology leads to the instant case.

The Engelgau Patent

Engelgau filed the patent application on August 22, 2000 as a continuation of a previous application for U.S. Patent No. 6,109,241, which was filed on January 26, 1999. He has sworn he invented the patent's subject matter on February 14, 1998. The Engelgau patent discloses an adjustable electronic pedal described in the specification as a "simplified vehicle control pedal assembly that is less expensive, and which uses fewer parts and is easier to package within the vehicle." Claim 4 of the patent, at issue here, describes:

A vehicle control pedal apparatus comprising:

- a support adapted to be mounted to a vehicle structure;
 - an adjustable pedal assembly having a pedal arm moveable in for[e] and aft directions with respect to said support;
 - a pivot for pivotally supporting said adjustable pedal assembly with respect to said support and defining a pivot axis; and
 - an electronic control attached to said support for controlling a vehicle system;
- said apparatus characterized by said electronic control being responsive to said pivot for providing a signal that corresponds to pedal arm position as said pedal arm pivots about said pivot axis between rest and applied positions wherein the position of said pivot remains constant while said pedal arm moves in fore and aft directions with respect to said pivot.

We agree with the District Court that the claim discloses “a position-adjustable pedal assembly with an electronic pedal position sensor attached to the support member of the pedal assembly. Attaching the sensor to the support member allows the sensor to remain in a fixed position while the driver adjusts the pedal.”

Before issuing the Engelgau patent the U.S. Patent and Trademark Office (PTO) rejected one of the patent claims that was similar to, but broader than, the present claim 4. The claim did not include the requirement that the sensor be placed on a fixed pivot point. The PTO concluded the claim was an obvious combination of the prior art disclosed in Redding and Smith, explaining:

Since the prior art references are from the field of endeavor, the purpose disclosed would have been recognized in the pertinent art of Redding. Therefore it would have been obvious to provide the device of Redding with the means attached to a support member as taught by Smith.

In other words Redding provided an example of an adjustable pedal and Smith explained how to mount a sensor on a pedal's support structure, and the rejected patent claim merely put these two teachings together.

Although the broader claim was rejected, claim 4 was later allowed because it included the limitation of a fixed pivot point, which distinguished the design from Redding's. Engelgau had not included Asano among the prior art references, and Asano was not mentioned in the patent's prosecution. Thus, the PTO did not have before it an adjustable pedal with a fixed pivot point. The patent issued on May 29, 2001 and was assigned to Teleflex.

The District Court's Opinion

The District Court determined, in light of the expert testimony and the parties' stipulations, that the level of ordinary skill in pedal design was “an undergraduate degree in mechanical engineering (or an equivalent amount of industry experience) and familiarity with pedal control systems for vehicles.” Following *Graham's* direction, the court compared the teachings of the prior

art to the claims of Engelgau. It found “little difference.” Asano taught everything contained in claim 4 except the use of a sensor to detect the pedal’s position and transmit it to the computer controlling the throttle. That additional aspect was revealed in sources such as the ‘068 patent and the sensors used by Chevrolet.

Under the controlling cases from the Court of Appeals for the Federal Circuit, however, the District Court was not permitted to stop there. The court was required also to apply the TSM test. The District Court held KSR had satisfied the test. It reasoned (1) the state of the industry would lead inevitably to combinations of electronic sensors and adjustable pedals, (2) Rixon provided the basis for these developments, and (3) Smith taught a solution to the wire chafing problems in Rixon, namely locating the sensor on the fixed structure of the pedal. This could lead to the combination of Asano, or a pedal like it, with a pedal position sensor.

The conclusion that the Engelgau design was obvious was supported, in the District Court’s view, by the PTO’s rejection of the broader version of claim 4. Had Engelgau included Asano in his patent application, it reasoned, the PTO would have found claim 4 to be an obvious combination of Asano and Smith, as it had found the broader version an obvious combination of Redding and Smith. As a final matter, the District Court held that the secondary factor of Teleflex’s commercial success with pedals based on Engelgau’s design did not alter its conclusion.

The Federal Circuit's Opinion

With principal reliance on the TSM test, the Court of Appeals reversed. It ruled the District Court had not been strict enough in applying the test, having failed to make “findings as to the specific understanding or principle within the knowledge of a skilled artisan that would have motivated one with no knowledge of the invention to attach an electronic control to the support bracket of the Asano assembly.” The Court of Appeals held that the District Court was incorrect that the nature of the problem to be solved satisfied this requirement because unless the “prior art references address[ed] the precise problem that the patentee was trying to solve,” the problem would not motivate an inventor to look at those references.

Here, the Court of Appeals found, the Asano pedal was designed to solve the “constant ratio problem” -- that is, to ensure that the force required to depress the pedal is the same no matter how the pedal is adjusted—whereas Engelgau sought to provide a simpler, smaller, cheaper adjustable electronic pedal. As for Rixon, the court explained, that pedal suffered from the problem of wire chafing but was not designed to solve it. In the court’s view Rixon did not teach anything helpful to Engelgau’s purpose. Smith, in turn, did not relate to adjustable pedals and did not “necessarily go to the issue of motivation to attach the electronic control on the support bracket of the pedal assembly.” When the patents were interpreted in this way, the Court of Appeals held, they would not have led a person of ordinary skill to put a sensor on the sort of pedal described in Asano.

That it might have been obvious to try the combination of Asano and a sensor was likewise irrelevant, in the court’s view, because “obvious to try”

has long been held not to constitute obviousness."

Analysis

The District Court was correct to conclude that, as of the time Engelgau designed the subject matter in claim 4, it was obvious to a person of ordinary skill to combine Asano with a pivot-mounted pedal position sensor. There then existed a marketplace that created a strong incentive to convert mechanical pedals to electronic pedals, and the prior art taught a number of methods for achieving this advance. The Court of Appeals considered the issue too narrowly by, in effect, asking whether a pedal designer writing on a blank slate would have chosen both Asano and a modular sensor similar to the ones used in the Chevrolet truckline and disclosed in the '068 patent. The proper question to have asked was whether a pedal designer of ordinary skill, facing the wide range of needs created by developments in the field of endeavor, would have seen a benefit to upgrading Asano with a sensor.

In automotive design, as in many other fields, the interaction of multiple components means that changing one component often requires the others to be modified as well. Technological developments made it clear that engines using computer-controlled throttles would become standard. As a result, designers might have decided to design new pedals from scratch; but they also would have had reason to make pre-existing pedals work with the new engines. Indeed, upgrading its own pre-existing model led KSR to design the pedal now accused of infringing the Engelgau patent.

For a designer starting with Asano, the question was where to attach the sensor. The consequent legal question, then, is whether a pedal designer of ordinary skill starting with Asano would have found it obvious to put the sensor on a fixed pivot point. The prior art discussed above leads us to the conclusion that attaching the sensor where both KSR and Engelgau put it would have been obvious to a person of ordinary skill.

The '936 patent taught the utility of putting the sensor on the pedal device, not in the engine. Smith, in turn, explained to put the sensor not on the pedal's footpad but instead on its support structure. And from the known wire-chafing problems of Rixon, and Smith's teaching that "the pedal assemblies must not precipitate any motion in the connecting wires," the designer would know to place the sensor on a nonmoving part of the pedal structure. The most obvious nonmoving point on the structure from which a sensor can easily detect the pedal's position is a pivot point. The designer, accordingly, would follow Smith in mounting the sensor on a pivot, thereby designing an adjustable electronic pedal covered by claim 4.

Just as it was possible to begin with the objective to upgrade Asano to work with a computer-controlled throttle, so too was it possible to take an adjustable electronic pedal like Rixon and seek an improvement that would avoid the wire-chafing problem. Following similar steps to those just explained, a designer would learn from Smith to avoid sensor movement and would come, thereby, to Asano because Asano disclosed an adjustable pedal with a fixed pivot.

Beverage Cosy Problem

The Party Popper consists of a foam bottle holder attached to a bottle opener. The Foozie consists of a foam can holder attached to a foam we're-number-one finger. The Sawzie consists of a foam can holder attached to a rotary saw. Assume that all of their individual components – foam can and bottle holders, bottle openers, foam we're-number-one fingers, and rotary saws – are prior art. Which of these inventions are obvious?

Battery Problem

Ivan Inventor is working on a new ultra-lightweight battery design for use in drones. Ivan has identified promising materials, but has not yet found a way to combine them safely in a sealed container. He is also concerned about the performance of the batteries in real-world conditions, when subject to the range of forces and impacts that a drone will be subjected to. He has enough funding to continue work for another 18 months; to raise more capital from his investors he will need to start booking sales. He is also afraid that others are working on ultra-lightweight batteries, some of which may have similar designs.

Counsel Ivan on how to design a suitable testing program, how to approach potential customers, and on when and how to file for patent protection.

KSR Problem

In relevant part, claim 4 of the patent in suit in KSR comprises:

- A pedal
- that is adjustable
- and has a fixed pivot,
- and a sensor
- that is in the pedal
- and is and mounted on a fixed position

The Court had before it a number of pieces of prior art, and had to decide whether claim 4 was obvious in light of them. Please look closely at the Court's descriptions of the following prior art:

- Asano
- Redding
- '936
- Smith
- '068
- Certain 1994 Chevrolet trucks
- Rixon

Which of the characteristics of claim 4, as listed above, do each of



The Popper



A Foozie



A Sawzie

these prior art references disclose? *Make a chart.* What improvements, if any, does each prior art reference suggest to a person having ordinary skill in the art. Using your chart as a guide, explain whether the Supreme Court’s analysis is persuasive.

c Analogous Arts

Not every prior art reference for Section 102 novelty purposes is automatically relevant for Section 103 nonobviousness purposes. Novelty is addressed to the invention itself: is it something genuinely new in the world? Nonobviousness is addressed to the PHOSITA: would the invention have become known anyway because a PHOSITA would have thought of it sooner or later? PHOSITAs are not walking encyclopedias; they know what people working in their fields and on their problems know. Textually, a PHOSITA is skilled in “the” art, not skilled in all arts. A great deal of useful innovation consists in recognizing that something trite and familiar in one field can have unexplored applications in another.

Thus a prior art reference can be considered under Section 103 when either (1) it is from the “same field of endeavor” as the invention, or (2) it is “reasonably pertinent to the particular problem” the inventor is attempting to solve.¹⁹⁹ For example, in *In re Clay*, the invention was a process for storing refined oil products. The problem it solved was that some storage tanks have a “dead volume”: the outlet port is above the tank bottom, so anything stored in the tank beneath the outlet cannot be removed. Clay’s invention solved the problem by using a gel to fill the dead volume.

The USPTO rejected Clay’s application as obvious in light of two previous patents. The Hetherington patent (No. 4,664,294) disclosed a process for filling the dead volume in a tank with an inflatable bag. The Sydansk patent (No. 4,683,949) disclosed a process for injecting a gel into underground rock formations to channel oil flow in a desired direction.

The Federal Circuit held that Hetherington was from the same field as Clay’s invention: the “storage of refined liquid hydrocarbons.” But Sydansk was not; it pertained to the “extraction of crude petroleum,” a different technical field. In a broader sense, all three pertain to the same vast fossil-fuel industry. But the industry’s vastness shows why this is too broad a classification. Geophysical engineers and chemical engineers have vastly different training and solve vastly different problems. That their common employer depends on both bodies of knowledge and expertise does not make those bodies the same.

As for the particular problem Clay was trying to solve, again Hetherington is on point. Both of them are directed to solving the dead-volume problem by filling the space with something. But again the Federal Circuit held that Sydansk was not, despite the USPTO’s argument that it too dealt with “maximizing withdrawal of petroleum stored in petroleum reservoirs.”

199. *In re Clay*, 966 F.2d 656, 569 (Fed. Cir. 1992).

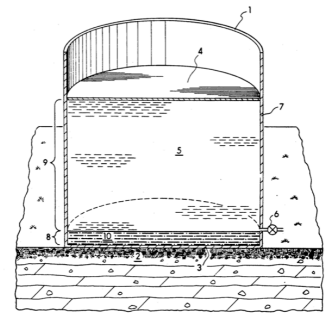

U.S. Pat. No. 5,172,825: Storage of a Refined Liquid Hydrocarbon Product (Clay)

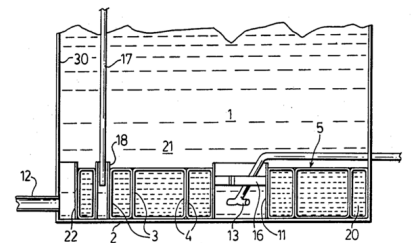

U.S. Pat. No. 4,664,294: Inventory Reduction by Displacement (Hetherington)

Sydansk is faced with the problem of recovering oil from rock, i.e., from a matrix which is porous, permeable sedimentary rock of a subterranean formation where water has channeled through formation anomalies and bypassed oil present in the matrix. Such a problem is not reasonably pertinent to the particular problem with which Clay was involved – preventing loss of stored product to tank dead volume while preventing contamination of such product.²⁰⁰

Thus, Sydansk was “non-analogous art” and could not be combined with Hetherington to render Clay’s claims obvious.

D Infringement: Similarity

Every intellectual property right has boundaries defined by some kind of similarity test. Information that is sufficiently similar to the right-owner’s information can infringe; information that is too dissimilar cannot.

In patent law, the boundaries of the owner’s rights are defined by the claims. . . The Federal Circuit has described claims as setting out the “metes and bounds” of the owner’s rights, like a description of the boundaries of real property.²⁰¹ *This is not the only way it could be.* Until 1870, patents were not required to have claims; the inventor simply described the invention in words. Design patents have drawings and only a formulaic placeholder “claim.” The fact that utility patent rights are defined by literally interpreted descriptions in words is a policy choice, not a fact of nature.²⁰²

The basic dogma of patent infringement is that an “accused” product or method (literally and directly) infringes a patent if it meets *every* limitation of *at least one* claim in the patent. Each claim is an arrow in the patentee’s quiver. Some of those arrows are broken (i.e., invalid). Some arrows miss the target (i.e. not be infringed). A claim only “hits” if every element is present in the accused product. But if the patentee hits with even one claim, that is enough for liability. (There is no bonus prize for multiple hits; the remedies are the same as for one.)

Remember that a dependent claim is *narrower* than the claim it incorporates. Thus, any product that infringes a dependent claim also infringes the claim it incorporates. It might seem that the patentee is therefore best off with no dependent claims, and only independent claims that are drafted as broadly as possible. The problem with this strategy is that a broader claim might be invalidated on one of the grounds we have seen, such as enablement, novelty, or nonobviousness. So the dependent claim might survive even when the claim it incorporates does not, and hit the sweet spot of being narrow enough to be valid but broad enough to be infringed. Giles S. Rich again: “The stronger a patent the weaker it is and the weaker a patent the stronger it is.”²⁰³

200. *Id.* at 569–60.

201. E.g., “All that part of the Southeast quarter of Section 19, Township 3 South, Range 1 East in the City of Huntsville, Madison County, Alabama, particularly described as beginning at the intersection of the East margin of Maysville Road and the South margin of U.S. Highway # 72 East, said point being located North 50 degrees 06 minutes East 144.0 feet from the most Northerly corner of Lot 23, Block 11 of the Chapman Heights Eighth Addition to the City of Huntsville as of record in Plat Book 3, Page 153 of the Probate records, Madison County, Alabama; said point is further described as being North 1 degree 00 minutes West 1235.0 feet North 49 degrees 42 minutes East 929.75 feet, North 50 degrees 45 minutes East 2391.50 feet and North 50 degree 06 minutes East 144.0 feet from the center of the West boundary of Section 30, Township 3 South, Range 1 East; thence from the place of beginning North 50 degrees 31 minutes East along the South margin of U.S. Highway # 72 East 1310.05 feet to a 6 inch × 6 inch concrete R.O.W. marker; . . . thence North 0 degrees 07 minutes East along the East margin of Maysville Road 400.00 feet to the place of beginning and containing 18.01 acres.” *Philpot v. State*, 843 So. 2d 122 (Ala. 2002).

202. see generally *fromerclaiming* (providing a taxonomy of different ways to define IP rights)

203. Giles S. Rich, *The Proposed Patent Legislation: Some Comments*, 35 GEO. WASH. L. REV. 641, 644 (1967).

Patent Litigation

There is a Seventh Amendment jury-trial right in patent-infringement cases, so they must be tried to a jury if either party insists. (Sometimes they do not, and agree to a bench trial before a judge.) If challenged by a motion for judgment as a matter of law, the jury's verdict is reviewed under a highly deferential "no reasonable jury" or "against the clear weight of the evidence" standard.

In *Markman v. Westview Instruments, Inc.*, the Supreme Court qualified this rule in a hugely consequential way.²⁰⁴ It held that *claim construction* – determining the meaning of a claim, including any specialized terms of art it uses – is a question of law to be decided by a court. Since claim construction is a matter of law, on appeal the Federal Circuit applies *de novo* review with no deference to the trial court's reasoning.

This split gives patent litigation a distinctive bifurcated character: first claim construction before the court, then infringement trial before a jury. Following discovery, the trial court will often hold a "*Markman*" hearing, with detailed motions, expert testimony, and oral argument, in which it construes the meanings of any disputed claim terms. Sometimes, the court's claim construction will be enough to decide the case on summary judgment. Otherwise, it will proceed to a jury trial on whether the defendant actually infringed the claims as construed.

This sounds logical enough, but it gives rise to a perverse consequence. There is no right to an immediate interlocutory appeal after claim construction but before jury trial. But since trial-court judges are for the most part not patent specialists, the Federal Circuit's views frequently differ. Thus, it is common for a patent case to proceed from a *Markman* hearing to a jury trial followed by an appeal in which the Federal Circuit reverses the trial court's claim construction, requiring a second jury trial.

1 Claim Construction

There is a broad consensus on three aspects of patent claim interpretation. First, claims should be given their "ordinary and customary meaning" to an audience of POSITAs, because "patents are addressed to and intended to be read by others of skill in the pertinent art."²⁰⁵ Second, since claims define the "metes and bounds" of a patent, it is important for claim construction to be clear, consistent, and predictable. And third, a patentee can "act as its own lexicographer"²⁰⁶ and define patent terms however it wishes, as long as it does so explicitly enough to override other meanings and clearly enough to avoid indefiniteness.

In short, claim construction would seem to be an ideal domain for textualism. But there is a complicating consideration: patents deal with highly technical subject matter, so the relevant terms of art are often not *legal* terms but *technical* terms in specific domains: polymer chemistry, power systems engineering, solid-state physics. The usual textualist assumption that dictionaries are a transparent source of objective meaning breaks down in complex technical fields; dictionaries, it turns out, also

204. *Markman v. Westview Instruments, Inc.*, 517 U.S. 370 (1996).

205. *Phillips v. AWH Corp.*, 415 F.3d 1303 (2005).

206. *Id.* at 1365.

require interpretation.

In 2002, in *Texas Digital Systems, Inc. v. Telegenix, Inc.*, the Federal Circuit adopted what looked like a standard textualist rule: claim interpretation should be based on the language of the claim, with a heavy reliance on dictionaries to fix the meaning of terms.²⁰⁷ But three years later, in *Phillips v. AWH Corp.*, the *en banc* Federal Circuit reversed course and announced that claim construction should be based primarily on *intrinsic* sources within the four corners of the patent itself, rather than *extrinsic* sources like dictionaries and technical treatises.²⁰⁸ *Phillips* establishes a hierarchy of sources to be used in interpreting claims:

- The language of a claim itself. “To take a simple example, the claim in this case refers to ‘steel baffles,’ which strongly implies that the term ‘baffles’ does not inherently mean objects made of steel.”
- Similarities and differences between the language of several claims, because the default assumption is that terms are used consistently through the claims. “For example, the presence of a dependent claim that adds a particular limitation gives rise to a presumption that the limitation in question is not present in the independent claim.”
- The patent’s specification, which may show that the inventor adopted a particular meaning for a term, or that they intentionally disavowed certain claim scope.
- The patent’s *prosecution history*, i.e. “the complete record of the proceedings before the PTO and includes the prior art cited during the examination of the patent.” While it may not be as clear as the claims or specification, the prosecution history details the negotiations between the applicant and USPTO about the patent’s scope, and thus can show how they understood claims’ meaning.
- Dictionaries and treatises which attempt to document the understandings of professionals in the relevant technical field.
- Expert testimony on the background of the field and how an invention works.

Thorner v. Sony Computer Entertainment America LLC

669 F.3d 1362 (Fed. Cir. 2012)

Craig Thorner and Virtual Reality Feedback Corporation (Appellants, collectively) accused Sony Computer Entertainment America LLC and a number of other Sony entities (Sony, collectively) of infringing claims of U.S. patent no.6,422,941 relating to a tactile feedback system for computer video games. The district court construed disputed claim terms and the parties stipulated to a judgment of noninfringement. Because the district court improperly limited the term “attached to said pad” to mean attachment only to an external surface and erred in its construction of the term “flexible”, we vacate and remand.

207. *Tex. Digit. Sys., Inc. v. Telegenix, Inc.*, 308 F.3d 1193 (Fed. Cir. 2002).

208. *Phillips*, 415 F.3d 1303.

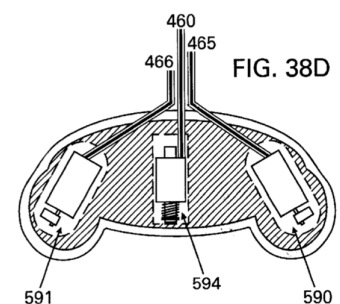

U.S. Patent No. 6,422,941 B1: Universal Tactile Feedback System for Computer Video Games and Simulations

Background

The '941 patent describes a tactile feedback system for use with video games. . . .

Each device includes some type of actuator that provides tactile feedback to a user in response to certain game activities. For instance, the actuators in hand-held game controller 598 may vibrate during a crash in a car racing game. Independent claim 1 requires "a flexible pad," "a plurality of actuators attached to said pad" and a control circuit that activates the actuators in response to game activity. The accused products are hand-held game controllers.

Two claim limitations are relevant to this appeal, "flexible pad" and "attached to said pad." The district court held that flexible does not mean simply "capable of being flexed." It reasoned that this definition was inappropriate because "many objects that are capable of being flexed are not flexible. A steel I-beam is capable of being flexed, but no one would call it 'flexible.'" The court thus construed the term to mean "capable of being noticeably flexed with ease."

The district court then turned to the construction of "attached to said pad." Appellants argued that attached should be given its plain and ordinary meaning and that an actuator can be attached to the inside of an object. Sony argued that "attached to said pad" should be construed as affixed to the exterior surface of the pad and does not include embedded within said pad. The court held that "the specification redefines 'attached' by implication." The court held that the word attached was limited to attached to the outside of an object because the embodiments in the specification consistently use the term "attached" to indicate affixing an actuator to the outer surface of an object and use the word "embedded" when referring to an actuator inside an object. For additional support for the notion that attached and embedded have different meanings, the court pointed to claim 1 which uses the word "attached" and dependent claim 10 which uses the word "embedded."

Following claim construction, the parties stipulated to noninfringement by the accused products. They stated that "under the Court's construction of the phrase 'attached to said pad,' Defendants have not infringed...." The stipulation further stated that the "parties reserve their rights to challenge this or any other construction of the disputed claim phrases of the '941 patent on appeal."

Discussion

The words of a claim are generally given their ordinary and customary meaning as understood by a person of ordinary skill in the art when read in the context of the specification and prosecution history. There are only two exceptions to this general rule: 1) when a patentee sets out a definition and acts as his own lexicographer, or 2) when the patentee disavows the full scope of a claim term either in the specification or during prosecution. The use of the term "attached" in this specification does not meet either of these exceptions.

To act as its own lexicographer, a patentee must clearly set forth a defini-

tion of the disputed claim term other than its plain and ordinary meaning. . It is not enough for a patentee to simply disclose a single embodiment or use a word in the same manner in all embodiments, the patentee must clearly express an intent to redefine the term. . . .

The standard for disavowal of claim scope is similarly exacting. Where the specification makes clear that the invention does not include a particular feature, that feature is deemed to be outside the reach of the claims of the patent, even though the language of the claims, read without reference to the specification, might be considered broad enough to encompass the feature in question. The patentee may demonstrate intent to deviate from the ordinary and accustomed meaning of a claim term by including in the specification expressions of manifest exclusion or restriction, representing a clear disavowal of claim scope. . . .

Mere criticism of a particular embodiment encompassed in the plain meaning of a claim term is not sufficient to rise to the level of clear disavowal. Even where a particular structure makes it particularly difficult to obtain certain benefits of the claimed invention, this does not rise to the level of disavowal of the structure. It is likewise not enough that the only embodiments, or all of the embodiments, contain a particular limitation. We do not read limitations from the specification into claims; we do not redefine words. Only the patentee can do that. To constitute disclaimer, there must be a clear and unmistakable disclaimer. . . .

Claim 1 of the patent at issue includes the disputed claim terms:

In a computer or video game system, apparatus for providing, in response to signals generated by said computer or video game system, a tactile sensation to a user of said computer or video game system, said apparatus comprising:

a flexible pad;

a plurality of actuators, attached to said pad, for selectively generating tactile sensation; and a control circuit ... for generating a control signal to control activation of said plurality of actuators....

1. ``attached to said pad''

Appellants argue that the district court erred by holding that the specification implicitly defined ``attached" to mean ``affixed to an exterior surface." They argue that the term does not require any construction and that the plain and ordinary meaning includes affixing an item to either an exterior or an interior surface. They contend that the specification explicitly states whether an attachment is to an interior or exterior surface: ``a vibratory actuator can be attached to [the] outer side of the throttle handle." They argue this shows that when the applicant wished to distinguish an internal from an external attachment, he did so with deliberate, express language. Thus, appellants argue that the specification contemplates ``attached" to have its plain and ordinary meaning—attached to either an interior or exterior surface. Finally, appellants argue that the fact that claim 10 includes the word ``embedded" does not mean that ``attached" can only mean connected to an exterior sur-

face. Rather, appellants argue that "embedded" is merely a narrower term that includes only attachment to an interior surface.

Sony responds that the patent clearly identified two different connections, "attached to" and "embedded within." It argues that in every instance where the specification uses the term "attached," it refers to an attachment to an outer surface. Conversely, in every embodiment where the actuator is placed inside a housing, the specification uses the term "embedded." See, e.g., '941 patent col.32 l.66 ("embedded within or attached to").

Our case law is clear, claim terms must be given their plain and ordinary meaning to one of skill in the art. The plain meaning of the term "attached" encompasses either an external or internal attachment. We must decide whether the patentee has redefined this term to mean only attachment to an external surface. As Sony argues, the specification repeatedly uses the term "attached" in reference to embodiments where the actuators are "attached to [an] outer side." In fact, the specification never uses the word "attached" when referring to an actuator located on the interior of a controller. We hold that this does not rise to the level of either lexicography or disavowal. Both exceptions require a clear and explicit statement by the patentee. It is not enough that the patentee used the term when referencing an attachment to an outer surface in each embodiment. In fact, the specification explains that an actuator was "attached to [an] outer surface." If the applicant had redefined the term "attached" to mean only "attached to an outer surface," then it would have been unnecessary to specify that the attachment was "to [an] outer surface" in the specification. We conclude that the term attached should be given its plain and ordinary meaning. The specification does not redefine attached nor is there any disavowal.

The fact that the specification uses the two terms "attached" and "embedded" as alternatives does not require a different result. There is nothing inconsistent about the applicant's use of the narrower term, "embedded," to describe embodiments affixed to an internal surface. The plain and ordinary meaning of embedded, "attached within," is narrower than "attached." Hence it makes sense that the applicant would want to use embedded when it meant to explicitly claim attached to the inside only. That does not mean the word attached automatically means attached to the external surface, as opposed to the broader plain meaning—attached to either the interior or exterior.

Other parts of the claim and specification also support this construction. The claim at issue requires a "flexible pad." The only embodiment in the specification that includes flexible material is the seat cushion 510 shown in Figure 2. The specification states that "the tactile feedback seating unit 510 is a semi-rigid flexible foam structure ... with a plurality of actuators embedded within the foam structure." Thus, the only flexible embodiment in the specification has embedded actuators. If we agreed with Sony that "attached" must mean attached to an outer surface, then the claim would exclude the only flexible embodiment disclosed in the specification. This is further evidence that the term "attached" should have its plain and ordinary meaning which includes either internal or external attachments.

We hold that the term "attached to said pad" should be given its plain

and ordinary meaning which encompasses either internal or external attachment. Because the parties based the stipulation of noninfringement on the district court's erroneous construction of this claim term, we vacate and remand.

II. "flexible pad" ...

Appellants argue that the term "flexible" simply means "capable of being flexed" and that the district court erred by requiring "capable of being noticeably flexed with ease." They note that the specification only uses the term "flexible pad" when referring to a "semi-rigid" structure and that a "semi-rigid" structure would certainly not be "noticeably flexed with ease."

Sony responds that although the specification uses the term to refer to a "semi-rigid" structure, that structure is made out of foam in every embodiment. It argues that foam is capable of being noticeably flexed with ease and thus a rigid, barely bendable material should not be considered "flexible." Sony also points to portions of the Markman hearing where the district court judge inspected one of the accused hard plastic controllers. The judge noted that the controller was rigid and "[i]f I try to flex this thing, I think that you're going to see it snap."

We agree with the appellants that the district court improperly limited the term. Neither the claims nor the specification requires the "flexible pad" to be noticeably flexed with ease. The specification says only that the flexible pad must be a semi-rigid structure. The task of determining the degree of flexibility, the degree of rigidity that amounts to "semi-rigid," is part of the infringement analysis, not part of the claim construction. The district court is of course free on summary judgment to decide that there is no genuine issue of material fact that the accused products in this case do not meet the plain and ordinary meaning of the term "flexible." We do not mean to suggest that summary judgment is improper in this case, only that claim construction is the wrong venue for this determination.

Wriggle-No-More Problem

The year is 1995. Loren Lukehart, inventor of U.S. Patent No. 4,800,666, reproduced above in section B, has sued the manufacturer of the Wriggle-No-More for infringement of the 666 patent. The defendant has indicated that it will argue that the Wriggle-No-More does not infringe because (1) the sand it contains is not "sharp," (2) the grain size of the sand it contains is 1/25th of an inch, and 25 is not "less" than 20 (3) its container does not have "lips" (defined as "the two fleshy parts which form the upper and lower edges of the opening of the mouth"), and (4) the length of its container is greater than the width of a "standard bait box."

Prepare to argue *both sides* of the claim-construction motion at the *Markman* hearing. What arguments will you make? What sources of evidence will you draw on?

2 Literal Infringement

There is surprisingly little to say about literal infringement. The parties will typically make their claim-construction arguments with a view toward the infringement analysis. Once claim construction is carried out, determining whether a product actually falls within the claim is a relatively straightforward question of fact. Whoever wins the claim-construction motion will often be in an excellent position at trial on the literal-infringement issue.

For example, consider *Angelo Mongiello's Children, LLC v. Pizza Hut, Inc.*²⁰⁹ The plaintiff held a patent on a method for making a stuffed-crust pizza by putting "individual food portions" on a dough base and then covering them with more dough. Its Claim 1 read:

1. A method of making a pizza comprising the steps of:
 - (a) forming a generally flat dough base;
 - (b) placing a plurality of separated individual food portions on the dough base such that, when the dough base is cut into substantially equally sized portions, each individual food portion is located upon a portion of each pie;
 - (c) covering each food portion with an unbaked dough section of sufficient dimensions to cover said food portion thereby forming a separate closed pocket about each food portion;
 - (d) covering the portions of the dough base which are not covered by said closed pockets with a layer of tomato sauce and cheese to form an unbaked pizza product; and
 - (e) baking the unbaked product to obtain a pizza.

In 1988, the plaintiff offered Pizza Hut a license to the patent, but Pizza Hut declined, saying it was "not a new concept for Pizza Hut." But in 1995, Pizza Hut launched its own "Stuffed Crust Pizza." The instructions it gave to its managers read:

- Place thumbs on edge of dough.
- Press dough ridge up the sides of pan.
 - Dough must extend just above rim of pan ($\frac{1}{4}$ "
- Evenly space five pieces of thawed mozzarella string cheese approximately a thumb's width apart along the outside edge of the dough
 - Place close to bottom of pan where edge meets.
- Use thumb and index fingers to stretch and fold edge of the dough over string cheese and press firmly to seal.
 - Dough overlap should be visible on both sides of thumb.
 - Keep stuffed edge at score line etched in pan to keep dough in round shape.
- Use thumbs to press and seal overlapped dough to bottom edge.
- Use thumbs to push stuffed edge out to edge of pan....

209. *Angelo Mongiello's Child., LLC v. Pizza Hut, Inc.*, 70 F. Supp. 2d 196 (E.D.N.Y. 1999).

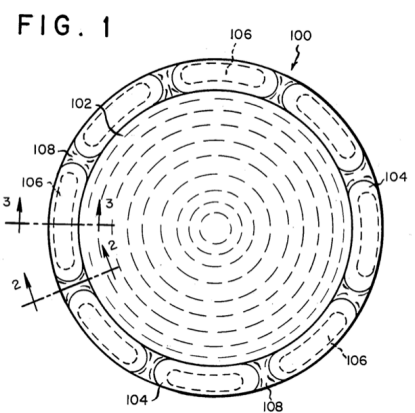

U.S. Pat. No. 4,661,361: Method of Making a Pizza

- All Stuffed Crust Pizzas are cut into 8 slices. If cheese is leaking through small hole in crust, begin cutting pizza at that spot.

Compare the italicized language from Claim 1 of the '361 patent to Pizza Hut's method. Do Pizza Hut's stuffed-crust pizzas have an "individual food portion . . . located upon a portion of each piece?"

No, they do not, because there is no way to cut a pizza with five pieces of mozzarella string cheese into eight slices such that "each" slice has an "individual food portion" of string cheese. The plaintiffs tried to get around this in claim construction by arguing that this limitation should be treated as an optional step that is satisfied as long as it is possible to cut the pizza with an "individual food portion" on "each" slice. (For a Pizza Hut pizza with five pieces of string cheese, that would mean five slices.) The court took the argument seriously enough to devote two pages of claim construction analysis to rejecting it.

When it was done, the court turned to literal infringement. Here is the *entirety* of its discussion:

In order to find literal infringement, the defendant must practice each and every element of the claimed method. Defendant's method, as described in the February 1995 manager's guide and the affidavit of Patricia Scheibmeir, a manager in defendant's research and development department, does not practice the "cutting" limitation as construed by the court. Although the Stuffed Crust Pizzas in question used five separate pieces of cheese, separated by a thumb's width, the instructions direct that the pizza be cut into eight slices using a "rocker blade," which cuts pizzas into an even number of slices. It is thus impossible for individual portions of cheese to be located on each portion of defendant's pizza.

Since defendant does not practice one of the essential limitations of the '361 patent, the court need not consider the other limitations before making a finding of no literal infringement.²¹⁰

And that's it. In practice, most difficult issues of literal similarity are front-loaded into claim construction.

Super Soaker Problem

This is claim 1 from U.S. Patent No. 4,239,129:

A toy comprising an elongated housing [case] having a chamber therein for a liquid [tank], a pump including a piston having an exposed rod [piston rod] and extending rearwardly of said toy facilitating manual operation for building up an appreciable amount of pressure in said chamber for ejecting a stream of liquid therefrom an appreciable distance substantially forwardly of said toy, and means for controlling the ejection.

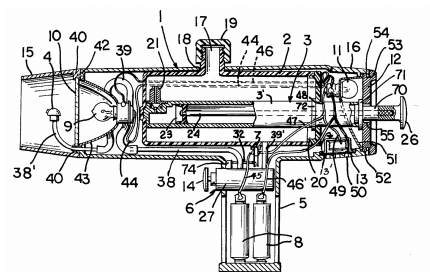

U.S. Patent No. 4,239,129: Water Pistol and/or Flashlight Structure

210. *Id.* at 206–07.

Does the Super Soaker 50 infringe this claim? Note that to use a Super Soaker, one fills it with water through the orange cap at the back top. Sliding the yellow handle back and forth along the white barrel pumps air into the green part, along with water. Pulling the trigger opens a valve that causes the air to press water forward, resulting in the Super Soaker's famed superior soaking ability. (Conventional water pistols didn't store up compressed air; they drove water out the barrel using the force of the trigger pull itself.)



Super Soaker 50

3 Doctrine of Equivalents

Are you sitting down? Good. Remember everything in the previous two sections about how patent infringement is defined by the “metes and bounds” of the claims, which are interpreted literally?

Well, the thing is, that's not actually, you know, *true*. In addition to literal infringement, which requires that every element of the claim be literally present in the accused device or method, there is also infringement under the *doctrine of equivalents*, or DOE. Under the DOE, it suffices if an “equivalent” to the element is present, even though that equivalent is not literally present. Thus, a claim to A + B + C can be infringed by a device with A + B + D, as long as the court finds that C \simeq D.

a Overview

Thus, the DOE does not change the every-element rule. Every element must still be present. It is just that the DOE relaxes the standard of what counts as an element from literal meaning to functional equivalency. More precisely:

The primary test for equivalency is the “function-way-result” or “triple identity” test, whereby the patentee may show an equivalent when the accused product or process (1) performs substantially the same function, (2) in substantially the same way, (3) to achieve substantially the same result, as disclosed in the claim. . . . Equivalency may also be proven where the differences between the invention as claimed and the accused product or process are insubstantial. In no case, however, may the doctrine of equivalents ignore the individual claim elements.²¹¹

Equivalency is assessed element-by-element, not for the claim as a whole. The question is whether there is an equivalent to a particular element in the accused device, not whether the accused device as a whole is equivalent.

One justification for the DOE, a substance-over-form rationale, focuses on infringers. As Justice Jackson explained in *Graver Tank & Mfg. Co. v. Linde Air Products Co.*:

But courts have also recognized that to permit imitation of a patented invention which does not copy every literal detail

211. *Abbott Lab's v. Sandoz, Inc.*, 566 F.3d 1282, 1296–97 (Fed. Cir. 2009) (numbering added).

would be to convert the protection of the patent grant into a hollow and useless thing. Such a limitation would leave room for – indeed encourage – the unscrupulous copyist to make unimportant and insubstantial changes and substitutions in the patent which, though adding nothing, would be enough to take the copied matter outside the claim, and hence outside the reach of law. One who seeks to pirate an invention, like one who seeks to pirate a copyrighted book or play, may be expected to introduce minor variations to conceal and shelter the piracy. Outright and forthright duplication is a dull and very rare type of infringement. To prohibit no other would place the inventor at the mercy of verbalism and would be subordinating substance to form. It would deprive him of the benefit of his invention and would foster concealment rather than disclosure of inventions, which is one of the primary purposes of the patent system.²¹²

Another justification focuses on patent applicants and has to do with the limits of language:

Unfortunately, the nature of language makes it impossible to capture the essence of a thing in a patent application. . . .

An invention exists most importantly as a tangible structure or a series of drawings. A verbal portrayal is usually an afterthought written to satisfy the requirements of patent law. This conversion of machine to words allows for unintended idea gaps which cannot be satisfactorily filled. Often the invention is novel and words do not exist to describe it. The dictionary does not always keep abreast of the inventor. It cannot. Things are not made for the sake of words, but words for things.²¹³

The language in the patent claims may not capture every nuance of the invention or describe with complete precision the range of its novelty. If patents were always interpreted by their literal terms, their value would be greatly diminished.²¹⁴

A classic early case on the DOE was *Winans v. Denmead*.²¹⁵ The patent claimed a railroad car “in the form of a frustum of a cone” (i.e., an upside-down truncated cone). The advantage of this shape is that the evenness of the shape and the tapering reduce the stress forces in the bottom corners of a rectangular car. The defendant built railroad cars in the shape of a frustum of an octagonal pyramid. That is, its shape was still tapered, but the cross section was an octagon, not a circle. The Supreme Court held that this could infringe: it carried cargo in the same way, had the same structural advantages, and used the same general kinds of shapes to achieve them.

212. *Graver Tank & Mfg. Co. v. Linde Air Prods. Co.*, 339 U.S. 605, 607 (1950).

213. *Autogiro Co. of Am. v. United States*, 384 F.2d 391, 397 (Ct. Cl. 1967).
 214. *Festo Corp. v. Shoketsu Kinzoku Kogyo Kabushiki Co.* (“*Festo I*”), 535 U.S. 722, 731 (2002).
 215. *Winans v. Denmead*, 56 U.S. (15 How.) 330 (1854).

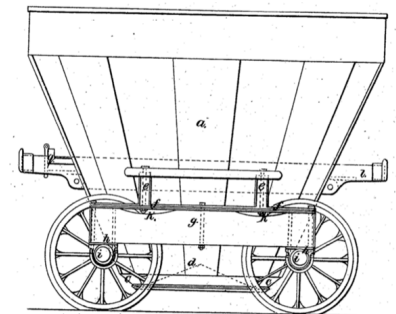

U.S. Pat. No. 5,175: Dumping Car

For a modern example of the DOE, take *Hughes Aircraft Co. v. United States*.²¹⁶ Donald D. Williams obtained a patent on a method for orienting a spacecraft. In his system, an on-board sensor would take observations of the sun and transmit the data to the ground. There, the ground crew could use the raw data to determine the spacecraft's orientation, and compute the necessary corrections to bring it back into the correct orientation. They would then send appropriate control signals back to the spacecraft. Williams filed for a patent in 1960. When the patent ultimately issued, it claimed, in relevant part (emphasis added):

- a. a body [i.e. the spacecraft] adapted to spin about an axis; . . .
- d. means disposed on said body for providing an indication to a location external to said body] of the instantaneous spin angle position of said body about said axis and the orientation of said axis with reference to a fixed external coordinate system;
- e. and means disposed on said body for receiving from said location control signals synchronized with said indication;

Using this system, NASA successfully launched the Syncom 2 satellite, the first geosynchronous satellite, in 1963. It later used similar methods on other spacecraft, including all-stars like Pioneer 10 (1972) and Pioneer 11 (1973). The difference was that these spacecraft had onboard computers powerful enough to compute their orientations. Thus, they could transmit their orientations to the ground, rather than the raw "instantaneous spin angle position" required by the claim. There could be no literal infringement because the computer was inside the craft, not "external" to it. The Federal Circuit found infringement under the DOE. It explained

Once an on-board computer became available, as Bryson said, "any intelligent engineer designing this [S/E] system would say 'Look, I don't need to send the value of that ISA position to the ground, it's right there in the spacecraft. I'll just key my firing signal to that on board the spacecraft'."

The S/E spacecraft are identical with the Williams satellite, except for the employment of sophisticated, post-Williams equipment (computers) to achieve attitude control in the basic manner taught by Williams. Advanced computers and digital communications techniques developed since Williams permit doing on-board a *part* of what Williams taught as done on the ground. . . .

Put another way, retention of the ISA position in an on-board computer, while transmitting sufficient information to enable the ground crew to use that computer-retained information to control the satellite, is the modern-day equivalent of providing an indication of ISA to ground as taught

216. *Hughes Aircraft Co. v. United States*, 717 F.2d 1351 (Fed. Cir. 1983).

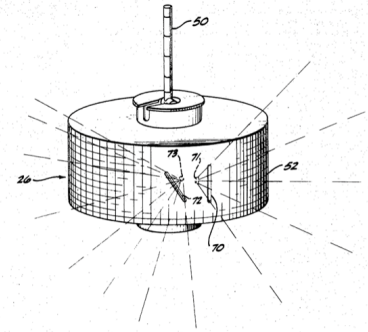

U.S. Pat. No. 3,758,051: Velocity Control and Orientation of a Spin-Stabilized Body

by Williams.²¹⁷

217. *Id.* at 1365–65.

Notice the use of the DOE to capture an improvement made possible by an “after-arising” technology, one not available to the inventor at the time of filing. Part of the rationale for the DOE is that it would have been unreasonable to expect Williams to anticipate a decade of developments in computing technology at the time he drafted his claims, especially given that *his invention did not pertain to computers*.

As you might predict, given the way that the DOE is defined, much of the action on the ground in applying it consists of arguments over whether a component of an accused product is equivalent to a claim limitation, or has the effect of reading that limitation out of the claim entirely. For example, in *Freedman Seating Co. v. American Seating Co.*, the Federal Circuit considered a patent on a “Stowable Seat” that could fold away, e.g., to make room for a wheelchair.²¹⁸ One of the distinctive features of the claimed seat was that it had no aisle leg, because such a leg would have to be folded out of the way when the seat was raised. Instead, the seat was supported by a mechanism with a diagonal support member that was fixed to the seat’s frame and “slidably mounted” to the seat. When the seat was raised it would slide along the support.

218. *Freedman Seating Co. v. Am. Seating Co.*, 420 F.3d 1350 (Fed. Cir. 2005).

The defendants also manufactured a stowable seat, the Horizon EZ Fold. Like Freedman’s seat, it had no aisle leg. But it used a different support mechanism: instead of sliding along the seat, the diagonal support was attached so that the seat would *rotate* about the attachment point. The mechanism still allowed the seat to fold out the way, by adding additional joints in the middle of the support mechanism.

The EZ Fold met every limitation of Claim 1 except possibly for the requirement that the support be “slidably mounted” to the seat. But it did not literally infringe, because rotation is not sliding. Thus, Freedman argued that the rotatably attached diagonal support was equivalent to a slidably attached diagonal support.

The Federal Circuit disagreed, saying that the “structural difference” between rotatable mounting and slidable mounting “is not a subtle difference in degree, but rather, a clear, substantial difference or difference in kind.”²¹⁹ The court elaborated:

219. *Id.* at 1361.

Freedman argues that the slider crank claimed in the ‘389 patent and the fourth link mechanism used in the EZ Fold function in the same way to produce identical results. Freedman asserts that this is because “both the infringing seat and the claimed structure of the ‘389 patent provide the moveable end of the support member with both translational and rotational motion relative to the seatbase.” The problem, however, is that taken to its logical conclusion, Freedman’s argument would mean that any support member capable of allowing translational and rotational motion would be equivalent to a support member “slidably mounted to said seatbase,” which reads “slidably mounted” completely out of the claims.²²⁰

220. *Id.* at 1361–62.

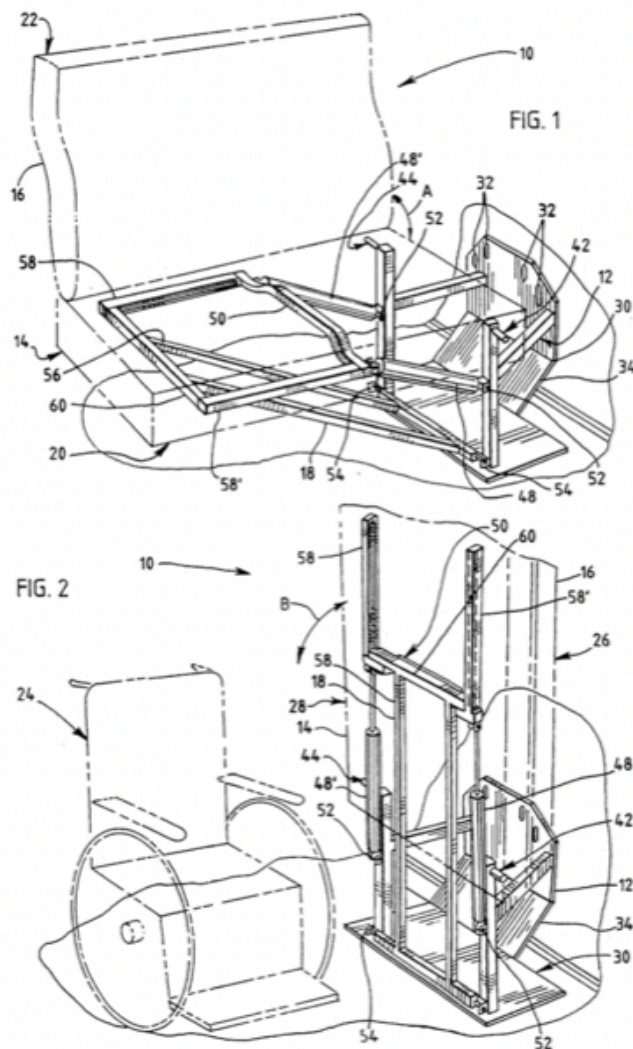

U.S. Pat. No. [extlinkhttps://patents.google.com/patent/US5492389A5,492,389](https://patents.google.com/patent/US5492389A5,492,389): Stowable Seat (Freedman)

This is plausible enough, but this same form of argument would also have said that in *Winans* a frustrum of an octagonal pyramid was not equivalent to a “frustrum of a cone.” After all, any design with both truncation and tapering would thus be equivalent to a design in the form of a “frustrum of a cone,” thereby reading “cone” completely out of the claim. So it is probably best to think of “reading a limitation out of the claim” as language courts use when they want to find an accused device not equivalent.

b Limitations

The potential unboundedness of the judicially-created doctrine of equivalents has led courts to fashion judicially-created limits on it.

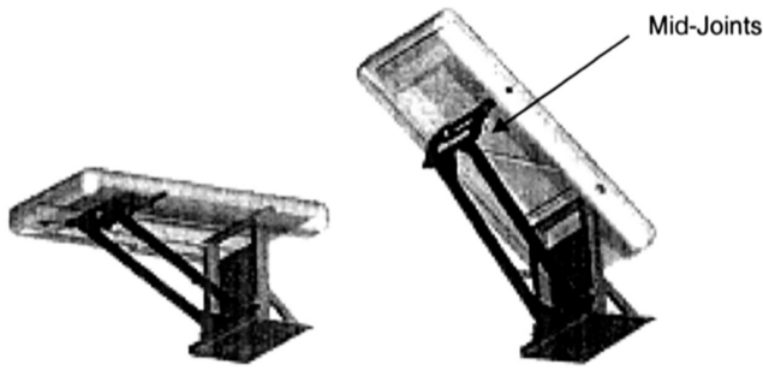

The Horizon EZ Fold

Prosecution-History Estoppel

One such doctrine is *prosecution history estoppel*, which prevents a patentee from narrowing a claim during prosecution and then using the DOE to recapture the same subject matter. The theory is that narrowing a claim is a concession to the USPTO that the amended claim does *not* reach as far as the unamended claim, and the patentee should be held to that concession. This is particularly important because a common reason to narrow a claim is to avoid the prior art, so allowing the patentee to use the DOE here would allow a claim to cover the prior art, violating the fundamental patent dogma that no patent can restrict others' right to practice what is already publicly known.

As an example of how the inquiry can get, consider *Warner-Jenkinson Co. v. Hilton Davis Chem. Co.*²²¹ Hilton Davis held Patent No. 4,560,746 on a process for purifying dyes through high-pressure filtration. During prosecution, it amended the claim to specify that the filtration take place "at a pH from approximately 6.0 to 9.0." A previous patent, the Booth patent, disclosed a filtration process at a pH above 9.0. Warner-Jenkinson developed its own dye-filtration process that was covered by the claimed process in all technical respects except that it took place at a pH of 5.0. There was no literal infringement, because 5.0 is not even approximately between 6.0 and 9.0, but Hilton Davis argued that there was equivalent infringement.

Prosecution history estoppel would definitely have applied to the upper limit of 9.0. That limit was added during prosecution to narrow the claim to avoid the Booth prior art, so the claim would have been unpatentable without the narrowing amendment. Thus, prosecution history estoppel would apply and the DOE could not be used to cover filtration at a pH greater than 9.0. But the record before the Supreme Court was silent as to why the lower limit was added; it might have been to avoid the prior art, or it might not have. So it remanded the case for further proceedings.

Although the most common use of prosecution history estoppel is when claims were amended to avoid a Section 102 rejection for lack of novelty over the prior art, it applies whenever "an amendment is made

221. *Warner-Jenkinson Co. v. Hilton Davis Chem. Co.*, 520 U.S. 17 (1997).

to secure the patent and the amendment narrows the patent's scope."²²² In *Festo Corp. v. Shoketsu Kinzoku Kogyo Kabushiki Co.*, the plaintiff's application for a patent on part of a conveying system initially contained an independent claim to "sealing means at each end" of a piston and a dependent claim "wherein the sealing means of the piston comprise sealing rings."²²³ The examiner rejected all of the claims as not enabled under Section 112, writing, "Exact method of operation unclear. Is device a true motor or magnetic clutch?" The plaintiff responded by replacing both claims with a single claim that included "first sealing rings" and "second sealing rings." The defendant's accused device had a single two-way sealing ring. Do you see why prosecution history estoppel would bar the patentee from treating a single sealing ring as equivalent to two sealing rings?

There is more. A narrowing amendment raises only a presumption that prosecution history estoppel applies. Some narrowing amendments might be made for reasons unrelated to patentability, so the patentee can rebut the presumption that it was by showing some other reason. And even if it was, prosecution history estoppel will not apply if the equivalent was "unforeseeable at the time of the application"; the amendment bears only a "tangential" relationship to the equivalent; or there is "some other reason suggesting that the patentee could not reasonably be expected to have described the insubstantial substitute in question."²²⁴ Is this any way to run a railroad?

The Disclosure-Dedication Rule

Another limit on the DOE is the disclosure-dedication rule. Where prosecution history estoppel applies when a claim is narrower than a *previous version of the claim*, disclosure dedication applies when a claim is narrower than the *specification*. "[W]hen a patent drafter discloses but declines to claim subject matter . . . this action dedicates that unclaimed subject matter to the public."²²⁵ In *Johnson & Johnston Associates v. R.E. Service Co.*, the patent concerned a method for making printed circuit boards by adhering them to a stiff substrate sheet during processing. The claims referred to "a sheet of aluminum" and "the aluminum sheet," but the specification stated, "While aluminum is currently the preferred material for the substrate, other metals, such as stainless steel or nickel alloys may be used." This, the Federal Circuit held, dedicated steel and nickel substrates to the public; the DOE could not be used to treat a steel substrate as equivalent to an aluminum substrate.

Prosecution history estoppel and the disclosure-dedication rule complicate a patent applicant's strategy during prosecution. An aggressive approach to prosecution – file broad claims, and then dial them back in response to rejections – can backfire by establishing the kind of narrowing amendments that give rise to prosecution history estoppel. Hilton Davis would potentially have been better off claiming the pH range from the start, because then it would have had a stronger argu-

222. *Festo I*, 535 U.S. 722, 736 (2002).

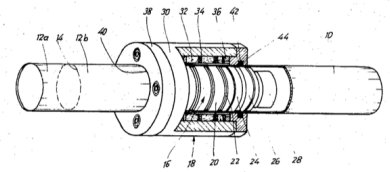

U.S. Pat. No. 4,354,125: Magnetically Coupled Arrangement for a Driving and a Driven Member

223. *Festo Corp. v. Shoketsu Kinzoku Kogyo Kabushiki Co.*, 344 F.3d 1359 (Fed. Cir. 2003).

224. *Festo I*, 535 U.S. at 740–41.

225. *Johnson & Johnston Assocs. v. R.E. Serv. Co.*, 285 F.3d 1046, 1054 (Fed. Cir. 2000).

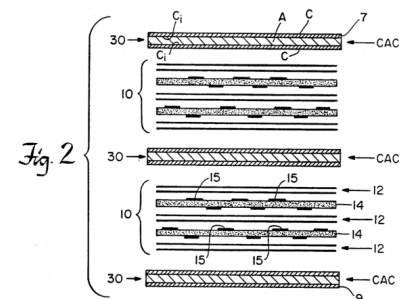

U.S. Pat. No. 5,153,050: Component of Printed Circuit Boards

ment for applying the DOE. And in *Johnson & Johnston Associates*, the patentee's garrulous disclosure had the effect of narrowing its claims by cutting off the DOE. Perhaps its claims should have been broader; perhaps the disclosure should have been narrower.

Prosecution-history estoppel and the disclosure-dedication rule raise a larger question: *Why bother with the rigor and exactitude of claim drafting, claim construction and literal infringement, if everything is just going back into the slop bucket of equivalent infringement at the end of the day?* The numerous limits on equivalent infringement are there to restore some semblance of rule-like certainty. But if equivalent infringement is both necessary and intolerable without well-defined limits, *why not make equivalent infringement the baseline and then come up with appropriate limiting doctrines?* How much simpler could patent law be if it were willing to take a step back from what Oskar Liivak calls "the cult of the claim?"²²⁶

226. Oskar Liivak, *Rescuing Patent Law from the Cult of the Claim*, 42 SETON HALL L. REV. 1 (2012).

Amgen Revisited Problem

What *should* Amgen have done in *Amgen*, given that it had identified 26 antibodies that bind to PCSK9, but did not know about the effectiveness of thousands of other antibodies? Consider the following strategies:

- Delay filing while it investigated the properties of other antibodies.
- Argue to the court for a claim construction that narrows the claim to cover only the 26 specific antibodies described in the specification.
- Write a specification that gives the amino-acid sequence for a single specific antibody, explain that it binds to PCSK9, and gives it a name. Then draft a claim that uses that name, and then argue for a claim construction that this includes all other antibodies that bind to PCSK9.
- Argue that other antibodies that bind to PCSK9 are equivalent to the ones it identified under the doctrine of equivalents.

What are the advantages and risks of these approaches? Can you think of other approaches?

E Infringement: Prohibited Conduct

Section 154 gives the owner of a patent "the right to exclude others from making, using, offering for sale, or selling the invention."²²⁷ Be clear on what this does and does not say.

A patent is not the grant of a right to make or use or sell. It does not, directly or indirectly, imply any such right. It grants only the right to exclude others.²²⁸

227. 35 U.S.C. § 154. Section 271(a) repeats the list in defining who is an infringer. § 271.

228. *Herman v. Youngstown Car Mfg. Co.*, 191 F. 579, 584 (6th Cir. 1911).

You can get a patent on an invention with illegal uses, but that patent doesn't give you the right to use the invention illegally. For example, a patent on a method of fishing does not override state game laws. As the Supreme Court put it in 1880 in *Webber*:

The patent for a dynamite powder does not prevent the State from prescribing the conditions of its manufacture, storage, and sale, so as to protect the community from the danger of explosion. A patent for the manufacture and sale of a deadly poison does not lessen the right of the State to control its handling and use. . . . Congress never intended that the patent laws should displace the police powers of the States, meaning by that term those powers by which the health, good order, peace and general welfare of the community are promoted. Whatever rights are secured to inventors must be enjoyed in subordination to this general authority of the state over all property within its limits.²²⁹

Similarly, an improvement patent on a device also covered by a previous patent does not let the new patentee ignore the old patentee's rights. Anyone who wants to make the device needs licenses from *both* patentees. If a technology standard is covered by hundreds of patents, anyone who wants to implement the standard needs licenses from the owners of every single one.

1 "making, using, offering for sale, or selling"

When looking at the details of the prohibited acts, it is useful to keep the distinction between products and processes in mind. In particular, a process cannot be "made" or "sold."

A product is "made" when all of its pieces are assembled into an operable whole. In *White v. Walbridge*, the patent covered lens holders and was about to expire.²³⁰ "The defendant has on hand and is making more lens-holder blanks, which can be completed into those that would infringe or those that would not; and has advertised that he would furnish those of the patent at reduced prices after the expiration of the patent."²³¹ *Held*, no infringement: "Till completed, these things would not infringe . . ."²³²

A process is "used" when all of its steps are performed. a product is "used" when it is put into service for the beneficial purpose of the patent.²³³ It is not a "use" to buy a patented device, to possess it, or to display it. So a defendant who had an infringing carbon monoxide sensor did not infringe by taking it to trade shows, but did infringe when they give demonstrations to potential customers at those trade shows.²³⁴

A "sale" of a product takes place when a contract is formed to transfer title or possessory rights. Thus, even if the product is actually transferred after the end of the patent term, if the contract of sale is formed during the patent term, infringement still takes place. Similarly, a license to an invention (e.g. a patent license to an improvement patent) is not a "sale" for infringement purposes.²³⁵ The licensee may infringe

229. *Webber v. Virginia*, 103 U.S. (13 Otto) 344, 348 (1880).

230. *White v. Walbridge*, 46 F. 526 (C.C.D. Vt. 1891).

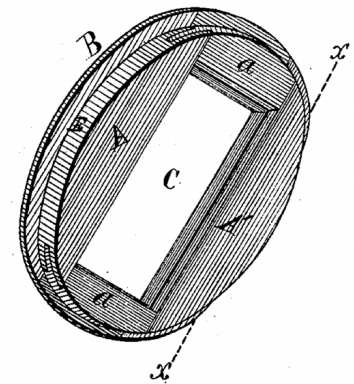

U.S. Pat. No. 151,576: Improvement in Stereoscope Lens-Frames

231. *Id.* at 526.

232. *Id.*

233. Query whether the definition of "use" for infringement purposes is the same as the definition of "utility" for patentability purposes.

234. *Quantum Grp. Inc. v. Am. Sensor Inc.*, No. 96 C 0761, 1998 WL 766707 (N.D. Ill. Apr. 10, 1998).

235. Note the symmetry between the "on sale" bar and "sale" as infringement.

the patent as soon as they start making the device, and the licensor may be secondarily liable for actively inducing infringement, but the license itself is not an infringing sale. On the other hand, a lease or license to use a specific physical device under the possession or control of the lessor or licensor is probably enough of a transfer of rights in tangible personal property to constitute an infringing “sale.”²³⁶

In practice, Congress took much of the weight off the definitions of “making,” “using,” and “selling” by adding “offering for sale” to the definition of infringement in 1996. Certainly an offer in the sense of state contract law – an offer to provide goods at a specified price, which will become a mutually binding contract immediately upon a buyer’s acceptance – is an offer for sale. But there is Federal Circuit authority that a patent-law “offer to sell” can be broader. For example, letters describing the patented devices and listing their prices, but stating that they were mere solicitations for the recipients to submit offers to purchase, were still infringing offers to sell.²³⁷ There isn’t much caselaw on point, but it appears that only products can be offered for sale; for the same reason that a process cannot be “sold,” it cannot be “offered for sale.” The Patent Act also resolves a potential timing question about offers for sale: an offer for sale only infringes if “the sale will occur before the expiration of the term of the patent.”²³⁸

At least officially, there is no *de minimis* exception to patent infringement.²³⁹ It is irrelevant if the defendant made only a small quantity of infringing product, or that it used a infringing method only briefly, or that its sales were commercially insignificant. These are all still infringement. Of course, *de minimis* infringement may give rise to small damages, but it is still infringement.

2 Intent

It is typically said that patent infringement is “strict liability.” That is, “[A]n infringement may be entirely inadvertent and unintentional and without knowledge of the patent.”²⁴⁰ Saurabh Vishnubhakat argues that this is slightly misleading. Based on a reading of the (limited) case law, he claims that one who does not even intend to take the actions described by the claims is not an infringer, just as someone who is blown into another by a gust of wind does not commit the tort of battery.²⁴¹ But otherwise, being ignorant of the patent is no defense, and neither is attempting but failing to implement a workaround that avoids its claims. In other words, a patent puts the world on notice. Potential defendants are expected to perfectly search the patent database, and to correctly interpret the scope of the claims of the patents they find there.²⁴²

3 Proof of Copying

All of the exclusive rights in patent pose straightforward factual questions: e.g., did the defendant make this device, or not? As such, they raise no distinctive proof problems, and ordinary rules and procedures of evidence are used to resolve them.

236. There is a frustrating ambiguity two meanings of “license”: a license to personal property versus a license to an IP right.

237. 3D Sys., Inc. v. Aarotech Lab’s, Inc., 160 F.3d 1373 (Fed. Cir. 1998).

238. patent271 at /i

239. Abbott Lab’s v. Sandoz, Inc., 566 F.3d 1282 (Fed. Cir. 2009).

240. Blair v. Westinghouse Elec. Corp., 291 F. Supp. 664, 670 (D.D.C. 1968).

241. Saurabh Vishnubhakat, *An Intentional Tort Theory of Patents*, 68 FLA. L. REV. 571 (2016).

242. See Patrick R. Goold, *Patent Accidents: Questioning Strict Liability in Patent Law*, 95 IND. L.J. 1075 (2020) (arguing that a negligence rule would be better).

Note that the definition of direct infringement – “*whoever* without authority makes, uses, offers to sell, or sells any patented invention”²⁴³ – is absolute. It contains no requirement that the defendant have copied *from the plaintiff*, as trade secret and copyright do. Thus, there are no difficult questions about the source of the defendant’s information. Indeed, “evidence of copying is of no import on the question of whether the claims of an issued patent are infringed, either literally or by equivalents.”²⁴⁴ Independent reinvention is not a defense to patent infringement.

F Secondary Liability

Section 271 of the Patent Act contains two explicit secondary liability provisions:

- (b) Whoever actively induces infringement of a patent shall be liable as an infringer.
- (c) Whoever offers to sell or sells . . . a component of a patented machine, manufacture, combination or composition, or a material or apparatus for use in practicing a patented process, constituting a material part of the invention, knowing the same to be especially made or especially adapted for use in an infringement of such patent, and not a staple article or commodity of commerce suitable for substantial noninfringing use, shall be liable as a contributory infringer.²⁴⁵

As their respective language indicates, Section 271(b) is an *inducement* liability provision; Section 271(c) is a *contributory* liability provision. But first, who precisely is a direct infringer?

1 Attribution and Divided Infringement

There are occasional issues about to whom to *attribute* directly infringing acts. In the context of sales and offers for sale, for example, it matters who is the seller or buyer. In *Blazer v. eBay, Inc., No. 1:15-CV-01059-KOB*, for example, the owner of a patent on a carpenter-bee trap sued eBay for sales of allegedly infringing products. An eBay listing is an offer to sell, but the court held that these offers were made by the eBay users who posted the listings, not by eBay itself.²⁴⁶ While eBay facilitated the listings – and so we should ask about its potential secondary liability – it was the sellers who would transfer title and possession to the infringing bee traps.

More difficult issues arise in cases of *divided* infringement, where multiple actors each perform some of the steps of a method claim.²⁴⁷ It seems like this shouldn’t even be a thing. The black-letter rule is that “direct infringement requires a single party to perform every step of a claimed method.”²⁴⁸ But this seems to invite an obvious dodge: the defendant contracts with a third party – perhaps a vendor, perhaps even its own customers – to perform a step or two, so that no single defendant practices the entire claimed method by itself.

243. 35 U.S.C. § 271(a).

244. *Depuy Spine, Inc. v. Medtronic Sofamor Danek, Inc.*, 567 F.3d 1314, 1336 (Fed Cir. 2009).

245. patent271

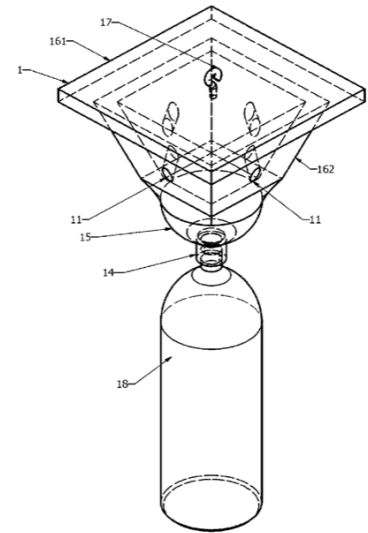

U.S. Pat. No 8,375,624: Carpenter Bee Traps

246. *Blazer v. eBay, Inc., No. 1:15-CV-01059-KOB*, 2017 WL 1047572 (N.D. Ala. Mar. 20, 2017).

247. Do you see why divided infringement is not an issue for product claims?

248. *Muniauction, Inc. v. Thomson Corp.*, 532 F.3d 1318, 1329 (Fed. Cir. 2008).

Thus, the Federal Circuit has attributed a third party’s performance of a method step to the defendant in two circumstances. First, when the defendant “directs or controls others’ performance,” it is regarded as having done those steps itself.²⁴⁹ For example, in the case that gave rise to this test, *Akamai Technologies, Inc. v. Limelight Networks, Inc.* (“*Akamai III*”), Akamai’s patent claimed methods for caching content on the Internet. Limelight had its customers “tag” the “content to be hosted and delivered by Limelight’s content delivery network.”²⁵⁰ As the court explained:

Specifically, Akamai presented substantial evidence demonstrating that Limelight conditions its customers’ use of its content delivery network upon its customers’ performance of the tagging and serving steps, and that Limelight establishes the manner or timing of its customers’ performance. Therefore, Limelight is liable for direct infringement.²⁵¹

The second prong of divided infringement, also announced in *Akamai III*, occurs when multiple actors “form a joint enterprise” The test for one, which has rarely been applied in detail, is drawn from the Restatement (Second) of Torts:

- (1) an agreement, express or implied, among the members of the group;
- (2) a common purpose to be carried out by the group;
- (3) a community of pecuniary interest in that purpose, among the members; and
- (4) an equal right to a voice in the direction of the enterprise, which gives an equal right of control.²⁵²

All of this is all well and good, but given that patent law has explicit statutory secondary-liability provisions, does it make sense to also have these common-law rules that shoehorn multi-party conduct into the direct-infringement boot? Or is the existence of these rules a tacit admission that perhaps the Patent Act’s secondary-liability provisions are too narrowly drawn?

2 Active Inducement

In 1952, Giles S. Rich, one of the drafters of Section 271(b), explained the idea behind active inducement:

Its intention is to hold liable the mastermind who plans the whole infringement and sits back and watches it happen, somehow himself managing to avoid either making, using or selling. This can happen in a variety of ways. The architects of a structure may be responsible, or a firm of engineers or the vendor of a kit sold with instructions, or of a machine which can operate only to perform a patented process. The possibilities are unlimited. These people are, legally speaking, joint tort feasons, and they ought to be held liable. So the

249. *Akamai Techs., Inc. v. Limelight Networks, Inc.* (“*Akamai III*”), 797 F.3d 1020, 1022 (Fed. Cir. 2015).

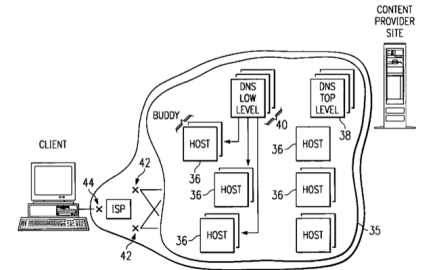

U.S. Pat. No. 6,108,703: Global Hosting System

250. *Id.* at 1024.

251. *Id.*

252. *Id.* at 1023.

active inducer is made and denoted an infringer.²⁵³

Liability under this provision requires the conjunction of three facts: (1) someone must have taken acts constituting direct infringement, (2) the defendant must have actively played some part in causing those acts, and (3) at the time of acting, the defendant must have at least known that those acts would constitute patent infringement.

Take first the requirement that there must have been direct infringement. This sounds tautological, but the difficulty of identifying a single direct infringer in cases of divided infringement is a non-trivial problem. The Federal Circuit first dealt with this issue *Akamai Technologies, Inc. v. Limelight Networks* by reasoning that Limelight and its customers would all infringe the patent if all the steps were carried out by the same person, so Limelight could be held liable as an inducing infringer without worrying about whether anyone at all was a direct infringer.²⁵⁴ The Supreme Court shot this ploy down in *Limelight Networks, Inc. v. Akamai Technologies, Inc.*, holding unambiguously that “inducement liability may arise if, but only if, there is direct infringement.”²⁵⁵ (Limelight still lost on remand under the rule that its customers’ actions under its control could be attributed it for purposes of *direct* infringement.²⁵⁶) There is no requirement that the direct infringer be joined as a defendant, or even identifiable.²⁵⁷

The defendant’s role can vary. Rich’s examples of architects and engineers involve defendants who draw up the design of infringing devices or processes, but leave the actual construction up to others. The “vendor of a kit sold with instructions” provides another with a roadmap to infringement. Merely buying a patented device is not by itself inducement, but if the defendant goes further, it may become an infringer. Here is a description of acts held to constitute inducement of a patent for making ductile tungsten (i.e., suitable for being drawn into a wire):

The De Forest Company maintains that it did not infringe because it went to a concern known as P. R. Mallory & Company, manufacturers of tungsten wire under a process now admitted to be the process of the patent in suit, and bought the wire over the counter as any innocent customer might purchase from stock in hand any other commodity which happened to be unlawfully made. If this position were supported by the evidence it would be sound, but we read the evidence in a different way. The Mallory Company was making tungsten wire of a certain size. A representative of the De Forest Company called upon it and indicated that his company wanted a wire of smaller size. The Mallory Company doubted its ability to make wire of that size but on an order from the De Forest Company it tried it out and found to the surprise of its employees that it could make it. From that time until the Mallory Company ceased to make wire, this wire of smaller size was regularly ordered by the De For-

253. Giles S. Rich, *Address to the New York Patent Law Association on the Patent Act of 1952*, 3 J. FED. CIR. HIST. SOC’Y 104, 113 (2009).

254. *Akamai Techs., Inc. v. Limelight Networks*, 692 F.3d 1301 (Fed. Cir. 2012).

255. *Limelight Networks, Inc. v. Akamai Techs., Inc.*, 134 S. Ct. 2111, 2117 (2014).

256. *Akamai III*, 797 F.3d 1020.

257. Can you think of reasons why a plaintiff might be unwilling or unable to sue the direct infringer, or unsatisfied with the results from doing so?

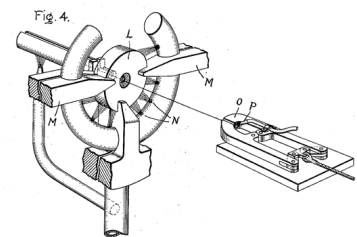

U.S. Pat. No. 1,082,933: Tungsten and Method of Making the Same for Use as Filaments of Incandescent Electric Lamps and for Other Purposes

est Company and regularly made by the Mallory Company in response to the orders and supplied the De Forest Company at the rate of about 100,000 meters a month.²⁵⁸

This test approaches but falls short of the direct-or-control standard for attribution under direct liability. The crucial fact seems to have been that De Forest knew, or must have known, that Mallory would infringe the patent in making the wire.

As this example shows, the required mental states associated with inducement infringement can be subtle. One the one hand, the defendant must *intend* the *factual* consequence that the acts that constitute infringement occur. In *Vita-Mix Corp. v. Basic Holding, Inc.*, Vita-Mix held a patent that covered “a method of preventing the formation of an air pocket around rotating blades positioned in a pitcher of a blender” by inserting a plunger above the blades, but *not* the use of a plunger to break up air pockets that already existed.²⁵⁹ Basic sold blenders with a stir stick; consumers who inserted the stir stick and left it alone infringed, but those who inserted the stir stick and scraped the sides of the blender did not. *Held*, no inducement:

Although the “default” vertical position of the stir stick may lead to infringing use under certain conditions, there is no evidence that Basic intends users to maintain the stir stick in this position. It is undisputedly possible to use the accused device as directed without ever practicing the claimed method. Additionally, the product design naturally encourages noninfringing use. The ball and socket joint facilitates stirring with a full range of motion, the interrupted ribbing encourages continuous contact between the stir stick and the sides of the pitcher, and the rubber o-ring encourages contact between the stir stick and the sides of the pitcher. Finally, pictures of the device in the product instructions, packaging, catalogues, and Basic’s own patent show the stir stick touching the sides of the pitcher.²⁶⁰

Similarly, in *Hewlett-Packard Co. v. Bausch & Lomb Inc.*, when Bausch & Lomb sold off its Houston Instruments division to Ametek, and the parties knew that Houston made a grit wheel plotter that might infringe a patent held by Hewlett-Packard, this was not inducement infringement. Judge Rich:

[I]t is clear that B & L was merely interested in divesting itself of Houston Instruments at the highest possible price. B & L had no interest in what Ametek did with Houston Instruments and certainly did not care one way or the other whether Houston Instruments, under Ametek’s ownership, continued to make grit wheel plotters. HP attempts to make much of the fact that part of the sale of Houston Instruments included the sale of specific plans for making grit wheel plotters as well as key personnel knowledgeable in this area.

258. *Gen. Elec. Co. v. De Forest Radio Co.*, 828 F.2d 641, 648 (3d Cir. 1928).

259. *Vita-Mix Corp. v. Basic Holding, Inc.*, 581 F.3d 1317 (Fed. Cir. 2009).

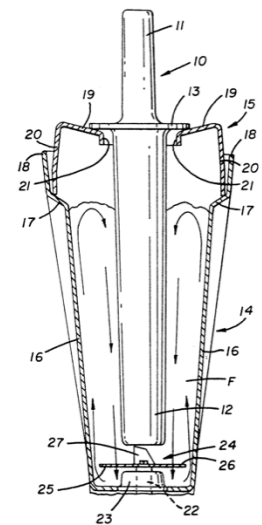

U.S. Pat. No. 5,302,021: Method of Preventing the Formation of an Air Pocket in a Blender



One of Basic’s accused blenders, the Smoothie Elite

260. *Id.* at 1328.

e.g., seeing someone living in a supposedly vacant house may provide reason to know of a potential adverse possession claim. These two standards are objective. Willful blindness is thoroughly subjective; it targets the person who deliberately avoids connecting the dots because they (correctly) fear what they will learn. It eliminates the incentive to avoid looking by treating the unknown-but-suspected fact as already known. Indeed, the defendant in *Pentalpha's shoes* might as well inquire, because there is a chance, however slim, that the patent it is worried about might not actually exist or might not cover the fryer.

3 Contributory Infringement

Contributory infringement under Section 271(c) is broader than active inducement in that it can be satisfied by mere *knowledge* rather than by intent; it is narrower in that it applies only to selling or offering to sell components, materials, and apparatuses and not to the wide range of conduct that active inducement can capture. Once again, it is useful to divide contributory infringement into three elements: (1) there must be a direct infringement, (2) to which the defendant has contributed by selling or offering to sell a material input, (3) with the appropriate level of knowledge.

Like active inducement, contributory infringement can only apply where there is some underlying direct infringement.²⁶⁷ This underlying infringement can be of a product claim (a “component of a patented machine, manufacture, combination or composition”) or of a method claim (“a material or apparatus for use in practicing a patented process”). The proof process that the underlying direct infringement has taken place is basically the same as for active inducement, and similarly, there is no requirement that the direct infringer be joined as a defendant.

The crucial language describing what kinds of things one may not sell to direct infringers is components “especially made or especially adapted for use in an infringement of such patent, and not a staple article or commodity of commerce suitable for substantial noninfringing use.”²⁶⁸ This looks like a two-element test, but it is really two mutually exclusive alternatives. *Either* an item is “especially made or especially adapted” for infringing use, *or* it is a “staple article or commodity of commerce” that is not. The idea is that suppliers should be free to sell general-purpose commodities that have substantial noninfringing uses without needing to inquire into their purchasers’ intended uses, but that they sell items only suitable for infringing use at their peril.

A noninfringing use is “substantial” when it is “not unusual, far-fetched, illusory, impractical, occasional, aberrant, or experimental.”²⁶⁹ The use of the stir stick in *Vita-Mix* to break up air pockets was a substantial use for the stir stick. In contrast, in *Golden Blount, Inc. v. Robert H. Peterson Co.*, a noninfringing use for a fireplace burner was insubstantial when it required disregarding the manufacturer’s instructions on how to assemble the complete device.²⁷⁰

Drawing the line frequently requires looking at the defendant’s

267. *Deepsouth Packing Co. v. Laitram Corp.*, 406 U.S. 518 (1972).

268. 35 U.S.C. § 271(c).

269. *Vita-Mix Corp. v. Basic Holding, Inc.*, 581 F.3d 1317, 1327 (Fed. Cir. 2009).

270. *Golden Blount, Inc. v. Robert H. Peterson Co.*, 438 F.3d 1354 (Fed. Cir. 2006).

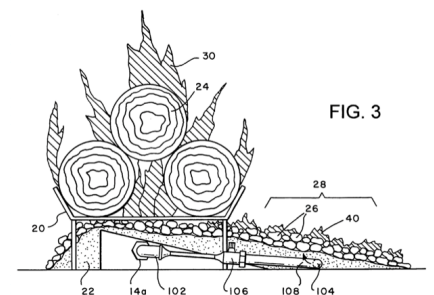

U.S. Pat. No. 5,988,159: Gas-Fired Artificial Logs and Coals-Burner Assembly

product-design decisions, because what is the relevant component, material, or apparatus depends on the context. In *Hodosh v. Block Drug Co.*, the patent claimed “a method for desensitizing teeth with a composition containing an alkali metal nitrate [e.g., potassium nitrate].”²⁷¹ Selling potassium nitrate is not contributory infringement, because it is widely used in fertilizers and fireworks. But selling a toothpaste containing potassium nitrate was contributory infringement, because in its toothpaste form, its only significant use is to desensitize teeth while brushing them.

For a modern example, consider *Lucent Technologies, Inc. v. Gateway, Inc.*²⁷² Lucent owned a patent claiming a method of entering information into a computer by displaying a tool specific to the field the user is entering data in. Lucent asserted that the date picker in Microsoft Outlook infringed these claims, *when used by Outlook users*. Thus, as to Microsoft, this was a contributory-infringement case, not a direct-infringement case.²⁷³

The key issue was whether the relevant product was Outlook as a whole, which had substantial noninfringing uses, or the date picker, which did not. The Federal Circuit agreed with Lucent that the right level of generality was the date picker. As it observed, if “Microsoft had offered the date-picker for sale as a separate download to be used with Outlook, there would be little dispute that Microsoft was contributing to infringement of the Day patent. . . . Inclusion of the date-picker feature within a larger program does not change the date-picker’s ability to infringe.”²⁷⁴

This gets at a key feature of software. Microsoft had the design freedom to include a date-picker feature, or to omit it. Thus, it makes sense to ask Microsoft to consider infringing and noninfringing uses not just when it decides whether or not to offer Outlook as a whole for sale, but also when it decides whether or not to include specific features in Outlook. Matters might be different if there were functional reasons that including feature X would also compel a defendant to include feature Y.

Finally, Section 271(c) requires the mental state of “knowing” that the product is suitable only for infringing uses. But again there is an ambiguity. Must the defendant know only the *factual* conclusion that the product is suitable only for particular uses (which just so happen, with or without their knowledge, to infringe), or must they also know the *legal* conclusion that those uses are infringing ones? In *Aro Mfg. Co. v. Convertible Top Replacement Co.*, the Supreme Court adopted the latter interpretation, holding that contributory infringement “require[s] a showing that the alleged contributory infringer knew that the combination for which his component was especially designed was both patented and infringing.”²⁷⁵ In cases where this element is in doubt, a cease-and-desist letter is a good way of calling a potential defendant’s attention to the patent and establishing the necessary foundation of knowledge.

271. *Hodosh v. Block Drug Co.*, 833 F.2d 1575 (Fed. Cir. 1987).

272. *Lucent Techs., Inc. v. Gateway, Inc.*, 580 F.3d 1301 (Fed. Cir. 2009). Lucent was spun off from AT&T’s research and manufacturing arm in 1996, but as its main business lines failed in the 2000s, it turned to asserting old Bell Labs patents.

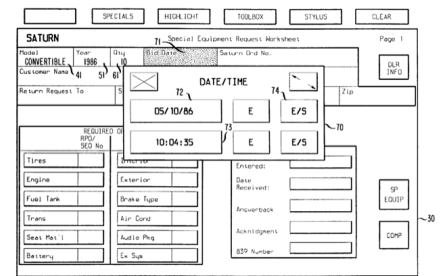

U.S. Pat. No. 4,763,356: Touch Screen Form Entry System

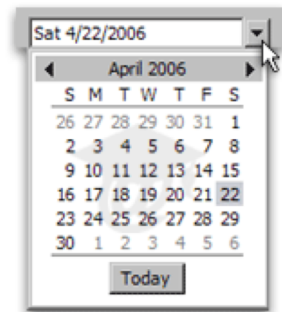

Outlook 2003 date picker

273. Why didn’t Lucent sue Outlook users?

274. *Lucent Techs.*, 580 F.3d at 1320, 1321.

275. *Aro Mfg. Co. v. Convertible Top Replacement Co.*, 377 U.S. 476, 489 (1964).

Bait Shop Problem

The year is 1995. You represent the Plano Bait Shop, a retailer with twenty-eight stores in Texas and the South, and its own house-branded line of fishing gear.

One of those products is an empty open-topped rectangular aluminum box, with a length slightly less than the width of a bait box, lips at each end that are the right shape to attach to the top edges of a bait box, and a detachable plastic cover. Some buyers take the boxes, fill them with sand, and use it to immobilize earthworms. Others take the boxes and fill them with fish hooks, washcloths, or other items.

Another product is a Fisher's Finger's Friend set, which consists of one of the above-described aluminum boxes and a sealed packet of sharp-grained sand. The packet is printed with instructions that illustrate rolling a worm in the sand and then illustrate putting the worm on a hook.

You have received a cease-and-desist letter from Loren Lukehart, inventor of U.S. Patent No. 4,800,666, reproduced above in section B, alleging that Plano and its customers infringe the 666 patent. Advise your client on whether it can continue selling these products. If not, what is the smallest change that the Plano Bait Shop can make to its products or to its business operations?

G Defenses

There are a few distinctive patent defenses. Far and away the most important are invalidity challenges and exhaustion. This section also discusses prior use rights and experimental use, both of which are marginal in practice. A few defenses unique to the biomedical context – medical activities and Hatch-Waxman submission-related activities – are discussed in the Biotechnology chapter.

1 Invalidity

Invalidity of any IP right is a complete defense to an infringement claim. If the right never existed in the first place, it cannot be infringed. Although technically the existence of the right is an element of the plaintiff's claim rather than an affirmative defense, it is functionally a defense because defendants will typically raise invalidity challenges as part of defending an infringement suit.

Patent is typical of many IP areas (in a way that trade secret is not) in that the plaintiff does not need to prove validity in full detail. Instead, they can rely on their issued patent as proof of validity; having proved patentability to the satisfaction of the USPTO, they need not reprove it to the satisfaction of the court. Indeed, they must do so: without an issued patent, they cannot sue for infringement at all.

A defendant can still raise an invalidity challenge in infringement litigation, but it is an uphill fight. Section 282 of the Patent Act provides:

A patent shall be presumed valid. . . . The burden of establishing invalidity of a patent or any claim thereof shall rest on the party asserting such invalidity.²⁷⁶

276. 35 U.S.C. § 282(a).

The Supreme Court has interpreted this language to mean that a defendant who wishes to prove invalidity defense must do so by *clear and convincing evidence*.²⁷⁷

277. Microsoft Corp. v. i4i Ltd. P’ship, 131 S. Ct. 2238 (2011).

As noted above, some grounds of unpatentability can be raised only before the USPTO and are not available as invalidity defenses. Failure to disclose best mode cannot be raised as a defense.²⁷⁸ Some observers have argued that lack of patentable subject matter challenge cannot be raised as an invalidity defense, reasoning that sections 102 and 103 are captioned “conditions for patentability” while section 101 is not.²⁷⁹ This argument has not succeeded in the courts, which universally allow section 101 challenges – indeed, they typically start their analyses there, even before considering other defenses.

278. 35 U.S.C. § 282(b)(3)(A).

279. David Hricik, *Why Section 101 is Neither a “Condition of Patentability” nor an Invalidity Defense* (Sept. 16, 2013), <https://patentlyo.com/hricik/2013/09/why-section-101-is-neither-a-condition-of-patentability-nor-an-invalidity-defense.html>. See generally 35 U.S.C. § 282(b)(2).

An invalidity finding can have catastrophic consequences for a patentee. While a finding of noninfringement simply means that the patentee loses that case against a particular defendant (and perhaps others on very similar facts), a finding of invalidity typically precludes the patentee from asserting the patent against *anyone*.²⁸⁰ If a patent is like a sword, the patentee takes the risk of breaking it permanently every time they wield it.

280. *Blonder-Tongue Lab’ys, Inc. v. Univ. of Ill. Found.*, 402 U.S. 313 (1971).

2 Exhaustion

The doctrine of *exhaustion* (or sometimes “first sale”) holds that when a patent owner sells an item embodying the patent, the patent owner’s rights in that specific item are “exhausted” and it is not infringement to resell or use that item. The privilege to use the item free and clear of the exhausted patent rights run with the item, so that anyone into whose hands it passes is free to use it without risk of infringement.

Exhaustion is sometimes said to reflect a policy judgment about the appropriate degree of economic reward for a patent: the patent owner should be entitled to a single sale, rather than charging each subsequent user, again and again indefinitely. But there is a counter regularly leveled at this argument: if downstream users must pay for downstream uses, the initial sale price will be reduced to reflect the item’s diminished resale value. But perhaps the patent owner will exploit buyers’ inattention to unanticipated future uses and spring its demands for later royalties as a unfair surprise. The economic back-and-forth is extensive.

So perhaps a better argument about patent exhaustion is a more conceptual one: it draws the line between personal-property and intellectual-property rights. The owner of a lawfully made and acquired item of personal property need not inquire as to unlicensed IP rights encumbering it. They are free to use it for the uses for which it was sold. The patent owner retains the exclusive right to make, use, and sell more items of that kind, but their rights in *this specific item* have terminated. Exhaustion is a simple rule with low information costs.

Exhaustion applies to an item as long as it “embodies essential features of the patented device” when sold, even if it is not yet in an infringing state.²⁸¹ In *United States v. Univis Lens Co.*, the patentee’s subsidiary sold unfinished lens blanks that would infringe only once ground into finished lenses. *Held*, the sale of blanks exhausted Univis’s patent rights because “the only use to which [the blanks] could be put”²⁸² was in practicing the patent. Observe how this rule mirrors, and only is justifiable in light of, the section 271(c) rule that the sale of items “especially adapted” for infringing use is contributory infringement.

The line between “this specific item” and “more items of that kind” can be surprisingly tricky to draw. Obviously the item owner is not permitted to set up their own widget factory and make thousands of widgets just because they have bought one patented widget. Neither can they set up a widget factory and leave it idle, buy one widget, use it until it breaks, run the production line to make a single replacement widget, use it until it too breaks, run the production line to make another replacement widget, and so on. They have paid for one patented widget, not the perpetual right to use exactly one widget at a time. They can use the same widget, but not new ones.

But what if they use the widget until it breaks, then *reassemble the broken pieces into a widget*? This is a metaphysical question about what constitutes the “same” widget.²⁸³ It is also a specific doctrinal dividing line. The item owner is permitted to *repair* the widget, but not to *reconstruct* it into a new one “after the entity, viewed as a whole, has become spent.”²⁸⁴

For an example of the repair/reconstruction line, consider *Sandvik Aktiebolag v. E.J. Co.*, which involved Sandvik’s patents (Nos. 4,222,690 and 4,381,162) on a drill with a carbide tip with specially shaped cutting edges.²⁸⁵ Over time, the drill tips wear down. After cutting through about a thousand inches of material, they need to be resharpened, i.e. the cutting edges must be worn down so that they have the correct angles. But after enough use, resharpening is not feasible. Either the tip has been chipped or cracked, or it has simply worn down so much that there is not enough surface on the cutting edges to resharpen.

The defendant, E.J., offered a drill repair service that would retip a Sandvik drill bit:

E.J.’s retipping process includes removing the worn or damaged tip by heating the tip to 1300 degrees Fahrenheit using an acetylene torch. E.J. then brazes in a rectangular piece of new carbide onto the drill shank. After the piece of carbide has cooled, E.J. recreates the patented geometry of the cutting edges by machining the carbide. This process includes: (1) grinding the carbide to the proper outside diameter; (2) grinding the carbide to a point; (3) grinding the rake surfaces of the new point; (4) grinding the center of the new point; and (5) honing the edges. In the final steps of the machining process, E.J. creates the cutting edges by following Sandvik’s

281. *United States v. Univis Lens Co.*, 316 U.S. 241, 249 (1942).

282. *Id.*

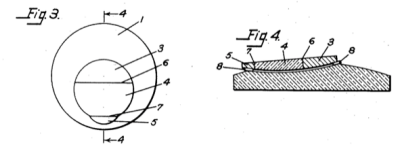

U.S. Pat. No 1,845,940: Lens

283. If this kind of philosophical question is interesting to you for its own sake, read Derek Parfit.

284. *Aro Mfg. Co. v. Convertible Top Replacement Co.*, 365 U.S. 336, 346 (1961).

285. *Sandvik Aktiebolag v. E.J. Co.*, 121 F.3d 669 (Fed. Cir. 1997).

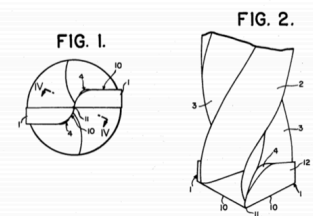

U.S. Pat. No 4,222,690: Drill Having Cutting Edges with the Greatest Curvature at the Central Portion Thereof

instructions for tip resharpening.²⁸⁶

Per the Federal Circuit, *resharpening* the drill tips was a permissible repair allowed by patent exhaustion, but *retipping* the drills was a forbidden reconstruction. It emphasized a number of factors:

[T]he nature of the actions by the defendant, the nature of the device and how it is designed (namely, whether one of the components of the patented combination has a shorter useful life than the whole), whether a market has developed to manufacture or service the part at issue and objective evidence of the intent of the patentee.²⁸⁷

Notice the emphasis on the useful life of the device and its components. The drill’s useful life was essentially the same as that of the tip; some customers simply threw away their Sandvik drills once the tips wore out. By way of contrast, in *Wilson v. Simpson*, the knives in the patentee’s machine would last for two or three months, but the rest of the machine would function for years if the knives were regularly replaced.²⁸⁸ Sandvik’s drill tips were not designed to be replacable; indeed, they were not detachable.

This all makes sense, but maybe Sandvik’s drill tips were designed not to be replaced so that patent exhaustion would not allow the owners to replace them. Sandvik did not make or sell replacement drill tips, or publish retipping instructions, but why would it? An aftermarket for retipping Sandvik drills is a market that others can compete in. By defining the patented article and its useful life as narrowly as it did, Sandvik reduced the effects of exhaustion on its business model. It could not eliminate those effects, even if it had wanted to: resharpening was still permissible repair. But it could still act strategically, even if the end result is wasteful, because it requires customers to throw away the rest of their perfectly good drills once the tip has worn down past the point of resharpening.

Exhaustion can also apply to method claims, even though it may appear that there is nothing to exhaust. In *Quanta Computer, Inc. v. LG Electronics, Inc.*, the Supreme Court held that method claims are “exhausted by the sale of an item that embodie[s] the method.”²⁸⁹ It reasoned that “Apparatus and method claims may approach each other so nearly that it will be difficult to distinguish the process from the function of the apparatus,” so that otherwise a patentee could always avoid exhaustion by redrafting a claim to the item itself as a claim to a method the item carries out.²⁹⁰ In *Quanta Computer* itself, LG held patents claiming methods of storing data in computer memory and licensed Intel to make and sell chips practicing the patents. This exhausted LG’s rights in the chips Intel sold; end users were free to use those chips, notwithstanding LG’s patents.²⁹¹ *Quanta Computer* also confirms that the first sale triggering exhaustion can be made by a licensee of the patentee, rather than by the patentee itself. What matters is that the sale is authorized, not who makes it.

286. *Id.* at 671–72.

287. *Id.* at 673.

288. *Wilson v. Simpson*, 50 U.S. (9 How.) 109, 125 (1850).

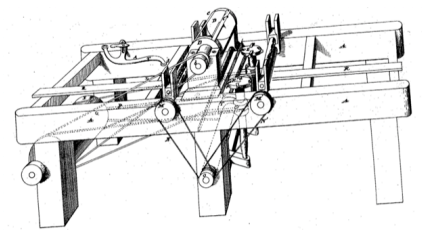

U.S. Pat. No. **U.S. Pat. No. Reissue 71**: Improvement in Machines for Planing, Tonguing, Grooving, and Dressing Boards, &c.

289. *Quanta Comput., Inc. v. LG Elecs., Inc.*, 553 U.S. 617, 629 (2008).

290. *Id.*

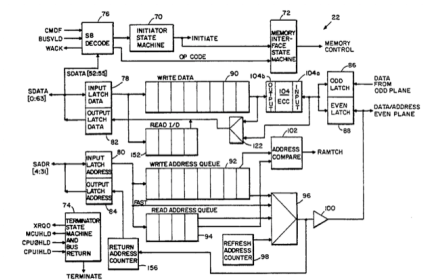

U.S. Pat. No **5,379,379**: Memory Control Unit with Selective Execution of Queued Read and Write Requests:

291. Compare *Lucent Technologies*; make sure you see why Microsoft’s sale of Office didn’t exhaust Lucent’s date-picker patent.

For many years, patent owners have attempted to avoid exhaustion by purporting to impose contractual restrictions when they sell an item. But per the Supreme Court, such restrictions are ineffective. Exhaustion still applies.

The leading case is *Impression Products, Inc. v. Lexmark International, Inc.*²⁹² Lexmark sells laser printers. Like many printer manufacturers, it sells the printers cheaply and makes most of its profits on toner. Because toner is so costly and so lucrative – toner costs more per milliliter than caviar, perfume, or vintage Dom Perignon – it is an attractive market for competitors.

To keep competitors from simply selling their own Lexmark-compatible toner cartridges, Lexmark owns a number of patents covering its toner cartridges and their use.²⁹³ So remanufacturers like Impressions obtain empty Lexmark cartridges, refill them with toner, and sell them at a discount to Lexmark's prices for new cartridges. Under cases like *Sandvik*, this is permissible repair. The toner itself is unpatented, and the cartridges can be easily refilled.

To keep remanufacturers from getting their hands on empty Lexmark cartridges, Lexmark created a "Return Program" in which purchasers received a discount in exchange for signing a contract promising to use the cartridge only once and to not to transfer it to anyone but Lexmark. When Impression continued to refill Lexmark cartridges, Lexmark sued for patent infringement, but the Supreme Court held that the restriction was ineffective:

We conclude that Lexmark exhausted its patent rights in Return Program cartridges the moment it sold them. The single-use/no-resale restrictions in Lexmark's contracts with customers may have been clear and enforceable under contract law, but they do not entitle Lexmark to retain patent rights in an item that it has elected to sell.²⁹⁴

The Federal Circuit had held to the contrary, reasoning that patent exhaustion is an implied license flowing to downstream users, but that patent owners were free to withhold that implied license if they structure their contracts with purchasers so that no downstream license passes. But this is the wrong way to think about exhaustion. It is not a default rule for interpreting licenses of the patentee's rights; it is a limit on what rights the patentee has in the first place.

Reusable Camera Problem

Your client, Déjà Vu Camera, makes disposable cameras reusable. These cameras consist of a cardboard container enclosing a roll of film, some inexpensive lenses, a small battery, a flash, a numerical counter, and a mechanism to advance the film. They are typically handed out at weddings, summer camps, and other social occasions for participants to take candid shots. To develop the film, a lab removes the roll, tearing through perforations in the cardboard container in the process. At this

292. *Impression Prods., Inc. v. Lexmark Int'l, Inc.*, 137 S. Ct. 1523 (2017).

293. This is the first, but hardly the last, time we will meet Lexmark's attempts to control the toner market via IP.



A (non-Impression) remanufactured Lexmark printer cartridge

294. *Impression Prods.*, 137 S. Ct. at 1531.

3 Free Expression

At first glance, patents might not appear to raise substantial First Amendment issues, as they deal with technology rather than with speech. But this view is mistaken. Some patents directly claim speech while others can be enforced ways that potentially restrict speech.²⁹⁵

As examples of patents that claim speech, consider No. **6,311,211**, which claims “sending an advocacy message to the selected user,” and No. **4,004,547**, on a cross-shaped door knocker. The former could be asserted to restrict political speech; the latter could be asserted to restrict religious speech. This is not to say that these patents should not have issued, or that their assertion would be unconstitutional, just that they clearly have free-expression implications. And, of course, patents on printing presses and other speech-carrying technologies can influence speech, as well. Similarly, advocacy groups have made vehement arguments that software and diagnostic-test patents violate the First Amendment. The argument against software patents, in brief, is that software is inherently speech because it is expression in the medium of code, so that claiming software (opposed to claiming hardware) necessarily claims speech itself. The short version of the argument against diagnostic patents is that they restrict physicians’ professional speech to patients.

As an example of how a non-speech-related patent can be asserted to restrict speech, consider *Popular Mechanics Co. v. Brown*, where *Popular Mechanics* published a picture and 20-line description of how to construct a garage “from which a sufficiently skilled reader might erect a structure embodying the idea of the patent.”²⁹⁶ The patentee sued for what we would today call active inducement. They lost, because there was no proof of any direct infringement. But notice that *Popular Mechanics* is part of “the Press” protected by the First Amendment, and its alleged infringement consisted *entirely of speech*, as indeed many active inducement claims will. Even where the defendant also provides a product or service, the line defining “inducement” will frequently turn on the defendant’s speech explaining how to do something or recommending a course of conduct.

But patent law has *no* doctrines specifically directed to expressive values, the way that copyright’s fair use doctrine is. Parties can and do make expressive arguments in support of their positions under other doctrines, but there is no separate free-expression defense.

4 Prior Use

Section 273(a) creates a “prior use defense” for a defendant who has commercially used a patented technology “acting in good faith” at least one year before the earlier of the patent’s filing date or public disclosure.²⁹⁷ The defense is restricted to processes, and to products used in processes. Both internal commercial uses and arm’s length sales are protected. However, the defendant must establish their prior use by clear and convincing evidence.

295. See generally Dan L. Burk, *Patents and the First Amendment*, 96 WASH. U. L. REV. 197 (2018); Tun-Jen Chiang, *Patents and Free Speech*, 107 GEO. L.J. 309 (2019).

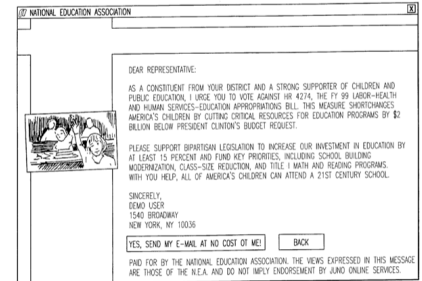

U.S. Pat. No. **6,311,211**: Method and Apparatus for Delivering Electronic Advocacy Messages

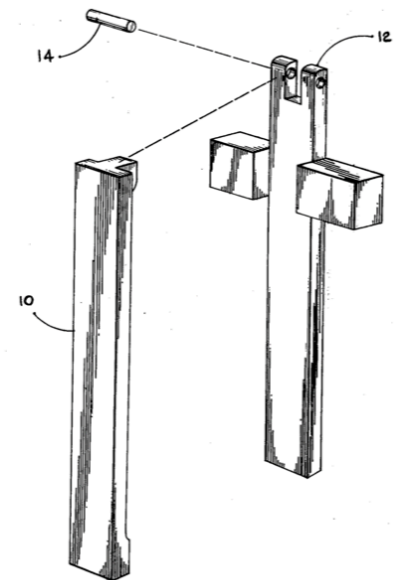

U.S. Pat. No. **4,004,547**: Christian Door Knocker

296. *Popular Mechs. Co. v. Brown*, 245 F. 859, 859 (7th Cir. 1917).

The prototypical prior-use defendant is a large manufacturer that uses a secret and potentially patentable process as part of its manufacturing operations. The dubious patentability means that it risks disclosing the details to competitors if it seeks patent protection. Under the pre-AIA first-to-invent system, this internal use gave it priority over later inventors, so its bets were hedged in case the process turned out to be patentable after all. But under the post-AIA first-to-file system, this secret use creates no prior art, so the competitor who files first could enjoin this longstanding use! Thus, the prior use defense was added to try to calibrate the balance between the incentives for secrecy and disclosure.

All that said, thousands of patent cases are filed yearly, but few defendants assert prior user rights. Why might that be? Consider . . .

Sausage Problem

Your client, Kemmit Meats, makes sausage, jerky, and other processed meat products. Some of its sausages taste better if they are held at relatively high temperatures in high-moisture environments during the curing process, but this poses an elevated risk of contamination because warm, moist, protein-rich environments are conducive to bacterial growth. About 8 years ago, a team of Kemmit food scientists and process engineers developed a method to accelerate the flavoring process by passing the products through a carefully arranged sequence of compartments at different temperatures and humidities. This method has been used in your Kemmit's factories since then.

You have just learned that a competitor, Agronomerica, has obtained a patent on a nearly identical method, filed for 18 months ago and granted 1 month ago. Agronomerica has sent Kemmitt a cease-and-desist letter offering to enter into a licensing arrangement. How will you respond?

5 Experimental Use

In 1813, Justice Story, riding circuit, held that it was not patent infringement to make a patented machine “merely for philosophical experiments, or for the purpose of ascertaining the sufficiency of the machine to produce its described effects.”²⁹⁸ This rationale evolved into a broader “experimental use” defense that protected activities to understand the invention and how it worked, as long as they were not tied too directly to plans to commercialize the technology. For example, in *Finney v. United States*, it was experimental use for NASA to try putting Velcro on an astronaut's space-suit gloves and on the handles of the two-wheeled vehicle he was to pull on the Moon, to see whether this would solve the problem of making the handles easier to grip.²⁹⁹ Presumably, experimental use would not have protected NASA if Alan Shepard had actually used the Velcro gloves on the Moon during the Apollo 14 mission.³⁰⁰

The Federal Circuit never liked the experimental use defense. The United States government asserted experimental use during extensive

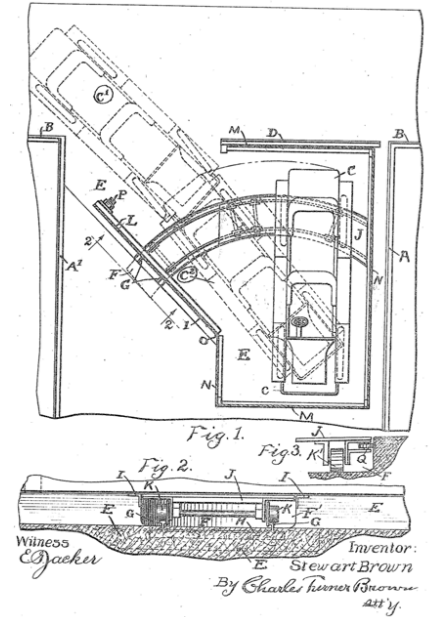

U.S. Pat. No. 1,175,506

SPECIAL DOOR FOR GARAGE FACING NARROW ALLEY

The problem of building a garage that is accessible to one driving a motor even though it opens on an alley

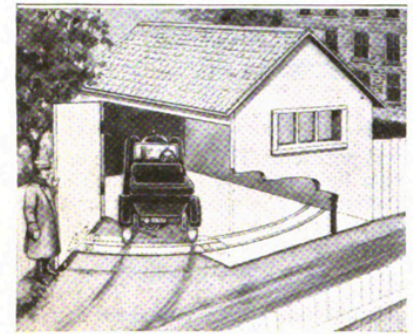

This Side Door, to Which a Low Platform Supported by Wheels is Attached, Makes a Garage Facing on a Narrow Alley Easily Accessible

so narrow that a car cannot back out of the structure, has been solved by designing a door at the side instead of the end of the garage. The hinged edge of the door is farthest from the alley. Projecting from, and fastened to, the inner side of the door near its free edge is a platform that lies close

Popular Mechanics, Aug. 1916, at 216

297. patent273 at /a

298. *Whittemore v. Cutter*, 29 F.Cas. 1120, 1121 (C.C.D. Mass. 1813).

testing of potential weapons systems and other military technologies it was considering buying; universities asserted it to cover their extensive research activities, arguing that almost any academic or non-profit uses were inherently “experimental.” In *Madey v. Duke University*, the Federal Circuit all but interred the doctrine when a former professor sued Duke University for continuing to use the laser he had left behind in his lab when he resigned, and on which he held several patents.³⁰¹ It held that while the experimental use doctrine would protect uses “solely for amusement, to satisfy idle curiosity, or for strictly philosophical inquiry,”³⁰² those phrases did not cover a major research university:

However, these projects unmistakably further the institution’s legitimate business objectives, including educating and enlightening students and faculty participating in these projects. These projects also serve, for example, to increase the status of the institution and lure lucrative research grants, students and faculty.³⁰³

Shrimp Deveining Problem

Your client, Southern Fruits De Mer (SFDM), is a regional seafood processor with plants in Louisiana, Mississippi, and Texas. For years, it has been buying handheld shrimp deveining tools from Seafood Supply Amalgamated (SSA). A few years ago, SSA introduced a new deveining tool with a double-curved blade that reduces friction and makes more precise cuts. Some of SFDM’s employees realized that the new tool design could be mounted horizontally above a moving conveyor belt. In this configuration, they could line up the shrimp with both hands and let the belt pull it through, resulting in substantially less cramping and fatigue. They installed this device in two of SFDM’s plants, increasing productivity and decreasing injury rates.

You have discovered that SSA holds a patent (the ‘003 patent) on the shape of the double-curved deveining-tool design. The double-curved blade design is essential to the functioning of the new device, because it automatically recenters the shrimp if it starts to pull to one side or the other. The device does not work effectively when used with older deveining-tool designs.

Advise SFDM on its IP strategy in relation to the existing ‘003 patent and the new deveining device.

Bizarro World Problem, Redux

Recall the Bizarro World Problem from the Undeveloped Ideas chapter. How does your advice change in a world that has trade-secret law and patent law?

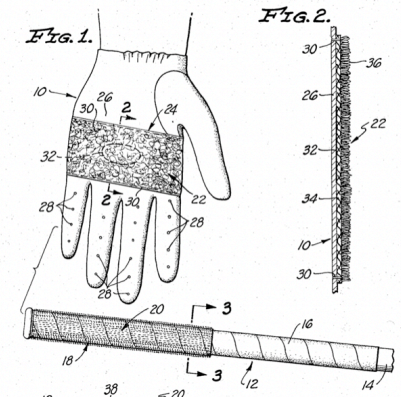

U.S. Pat. No 3,368,811: Interlocking Glove and Handle

299. *Finney v. United States*, 178 U.S.P.Q. 235 (Ct. Cl. 1973).

300. Wait? Would use on the Moon infringe at all? 35 U.S.C. § 105.

301. *Madey v. Duke Univ.*, 307 F.3d 1351 (Fed Cir. 2002).

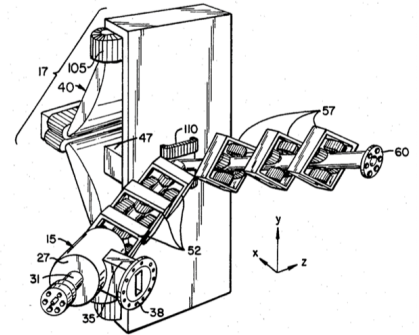

U.S. Pat. No 4,641,103: Microwave Electron Gun

302. *Id.* at 1362.

303. *Id.*